

Hardware Manual

Si-100

Programmable Motion Controller

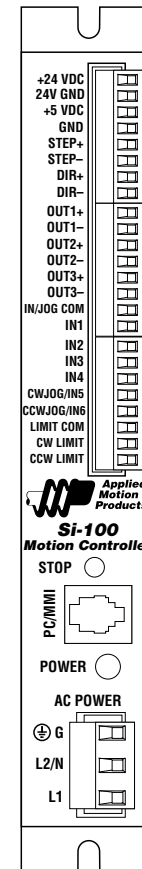

Copyright 1998

Applied Motion Products, Inc.

404 Westridge Drive Watsonville, CA 95076

Tel (408) 761-6555 (800) 525-1609 Fax (408) 761-6544



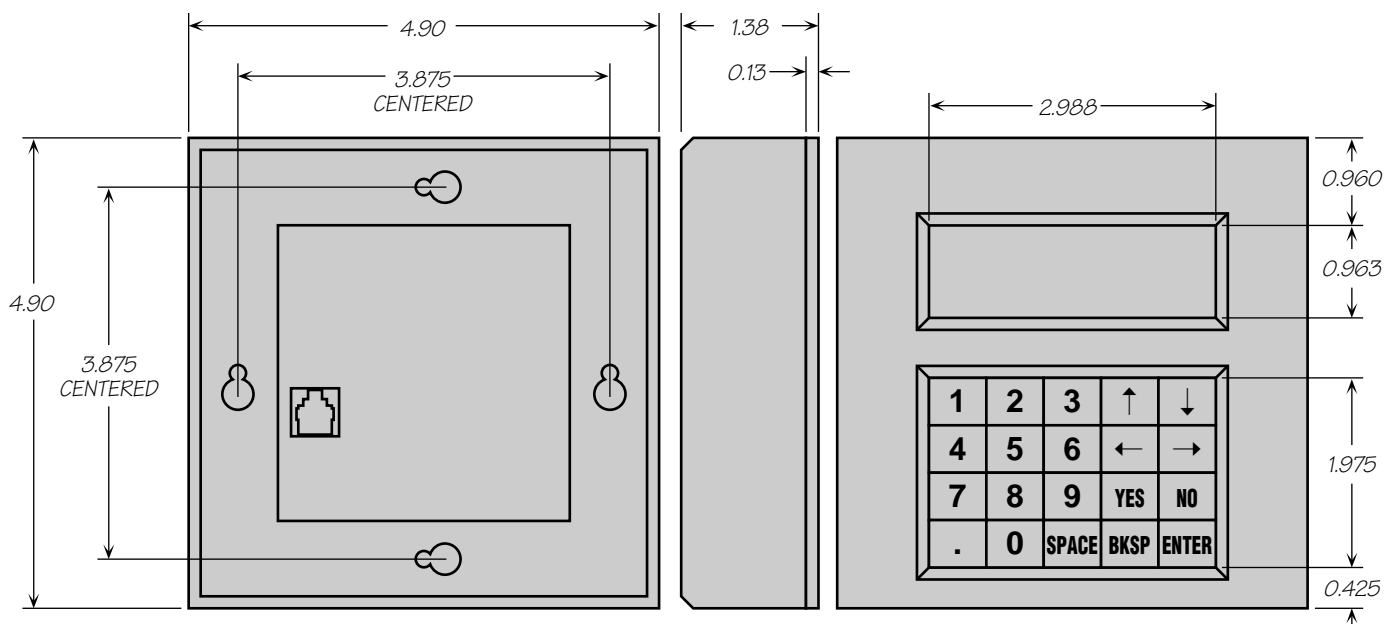

Mechanical Outline - Optional MMI

Technical Specifications

Power Supply	Linear, transformer based for high reliability and low noise. 110 or 220 VAC input, switch selectable. 50/60 Hz. 50 W max.
Output Voltages	24 VDC \pm 5%, 100 mA max. Self resetting fuse. 5 VDC \pm 5%, 100 mA max, including MMI which draws 45 mA. Self resetting fuse.
Inputs	IN 1-4, CW JOG, CCW JOG, CW LIMIT, CCW LIMIT: Optically isolated, 5 - 24V. Can be configured to accept sourcing or sinking signals. 2200 ohms input impedance.
Outputs	Optically isolated. 24V, 100 mA max. Can be individually configured to provide sourcing (PNP) or sinking (NPN) signals.
Microstepping	15 software selectable resolutions. Steps per revolution with 1.8 motor: 200, 400, 2000, 5000, 10000, 12800, 18000, 20000, 21600, 25000, 25400, 25600, 36000, 50000, 50800.
Motion Update	12800 Hz.
Physical	Constructed with heavy gauge steel housing. 1.25 x 8 x 3.86 inches overall. 2 lbs. 0 - 70°C ambient temperature range. Power/status LED. Mounting brackets included. See page 17 for detailed drawing .
Connectors	European style, pluggable screw terminal blocks, mating connectors included. Signal Input/output: Three 8 position. AWG 16 - 28 wire. AC Input: 3 position. AWG 12 - 24 wire. PC/MMI: RJ11C, cable & connectors included.
Fuses	Wickman TR-5 style, 0.25A fast acting. Order from Digikey (1-800-DIGIKEY), P/N WK3035.

Introduction

Thank you for selecting an Applied Motion Products motor control. We hope our dedication to performance, quality and economy will make your motion control project successful. If there's anything we can do to improve our products or help you use them better, please call or fax. We'd like to hear from you. Our phone number is (800) 525-1609 or you can reach us by fax at (408) 761-6544.

Features

- Powerful, flexible, easy to use indexer.
- Microsoft Windows-based software for easy set up and programming.
- Reliable, efficient, low noise linear power supplies provide 5V and 24V to the user, 100mA each.
- Connects by a simple cable to your PC for programming (cable included).
- Eight inputs for interacting with the user and other equipment.
- Three programmable outputs for coordinating external equipment.
- High speed, differential step & direction outputs interface easily to popular step motor and servo motor drives.
- Pulse rates to 2.5 MHz for high speeds at high resolutions.
- Accepts 110 or 220 volt AC power (factory preset for 110 volts).
- Sturdy 1.25 x 8 x 3.86 inch metal case with integral heat sink. Mounting brackets included.
- Pluggable screw terminal connectors for I/O and AC power (all mating connectors included).
- Bi-color (red/green) LED indicates power and indexer status.
- Optional man machine interface (MMI) allows operator to enter distances, speeds, loop counts and more.

Block Diagram

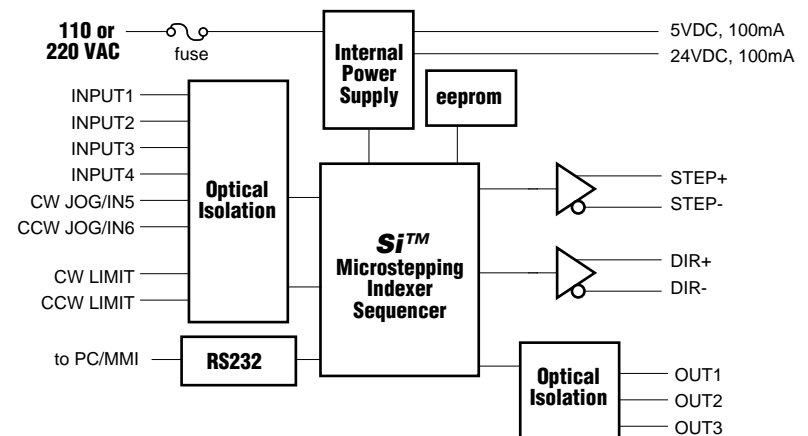

Getting Started

To use your Si-100 motor control, you will need the following:

- ✓ a power cable (line cord)
- ✓ a compatible step motor driver or pulse & direction servo driver
- ✓ a small flat blade screwdriver for tightening the connectors - an Applied Motion Products screwdriver suitable for this purpose is included with your drive.
- ✓ a personal computer running Windows 3.1 or Windows 95 with a 9 pin serial port (486 or better with 8 MB ram recommended)
- ✓ the Si Programmer software that came with your Si-100
- ✓ the programming cable that came with your Si-100
- ✓ Si Programmer manual

The sketch below shows where to find the important connection and adjustment points. Please examine it now.

All mating connectors are included.

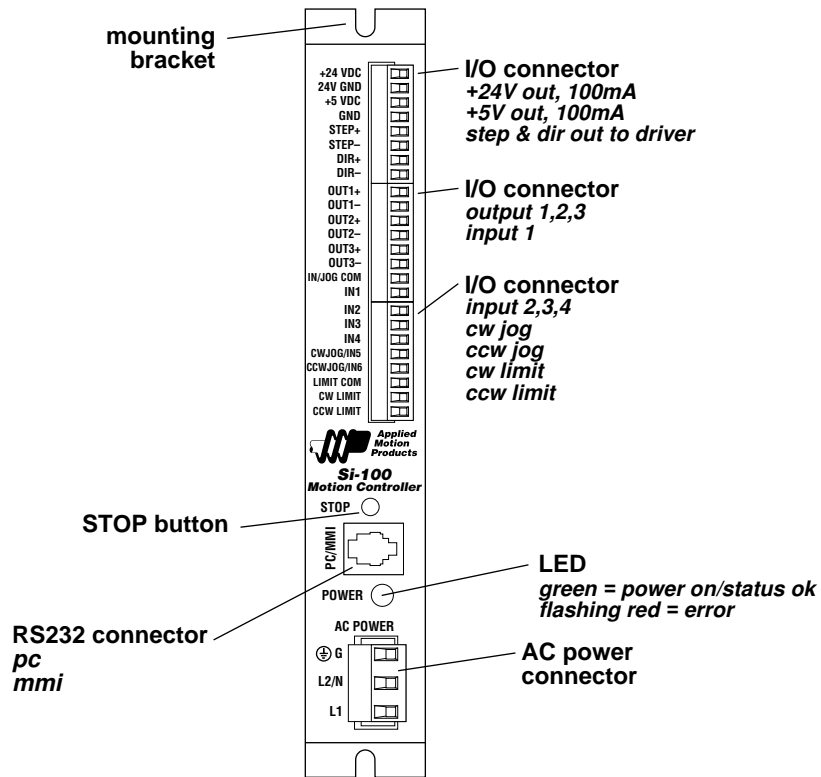

Recommended Step Motor Drivers

There are many step motor drivers available today, but none offer a better combination of price, performance and reliability than the Applied Motion Products drivers. The following chart summarizes the Applied Motion line. These units are usually available for same day or next day shipment.

Model Number	Input Voltage	Max Current (A)	Style	Steps per Revolution
1030D	12-30 VDC	1	DIN rail	200 - 400
2035	12-35 VDC	2	4" open frame	200 - 400
3535	12-35 VDC	3.5	4" open frame	200 - 400
3540 M	12-42 VDC	3.5	4" open frame	400 - 12,800
5560	24-60 VDC	5.5	6" open frame	200 - 12,800
7080	24-80 VDC	7	6" open frame	200 - 50,800
PD2035	110/220 VAC	2	packaged	200 - 400
PD5580	110/220 VAC	5.5	packaged	200 - 50,800
PD8400	110 VAC	8.4	packaged	200 - 50,800

Mechanical Outline: Si-100

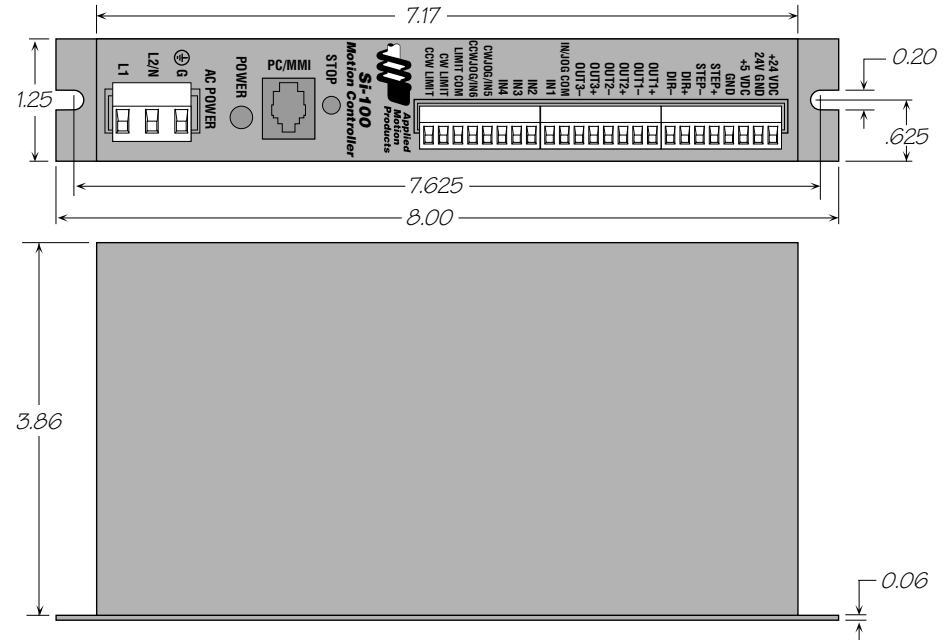

Flush Mounting

When you remove the MMI from the shipping carton, you will notice that it has two parts. The first is a fairly thin section that contains the keypad, display and some circuit boards. The other part is thicker and contains the telephone jack and a cable that connects to the thin part.

When you flush mount the MMI in a panel, only the thin section will stick out from your panel - the large portion mounts behind your panel. You'll need to cut a precise section from your panel. There is a cardboard template in your box for this purpose.

If you want the MMI to be dust proof and watertight, you must place the black rubber gasket between the thin part of the MMI and your panel. Assemble the two halves using the eight small screws.

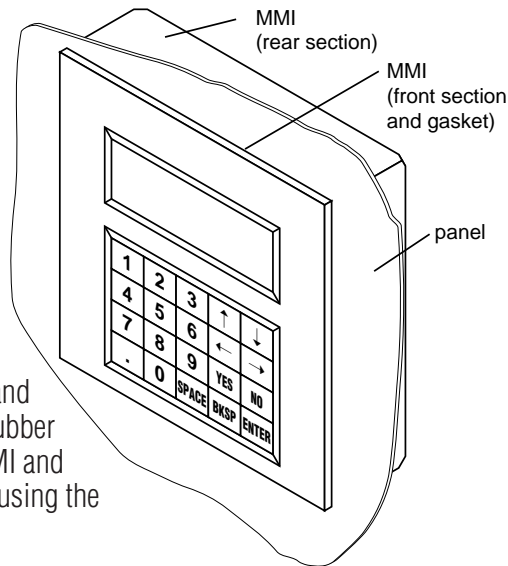

Surface Mounting

An easier way to mount the MMI is to bolt the two halves together ahead of time, using the eight small screws. If you want the MMI to be dust proof and watertight, put the black rubber gasket between the two halves before screwing them together.

Then cut a hole in your panel for the cable that runs between the MMI and the Si5580. The hole must be at least 5/8" in diameter for the connector to fit through. You will also need two holes that line up with the big mounting holes in the MMI. The mechanical outline on page 19 shows the location of the big mounting holes.

When you mount the MMI to your panel, you will need to use some kind of sealant to keep dust and liquid out. Silicone or latex caulking is okay, or you can make your own gasket from a sheet of compliant material like rubber or RTV.

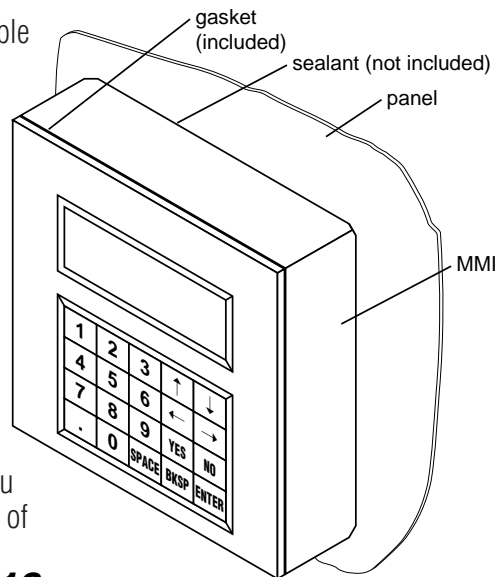

Connecting AC Power



If you plan to operate the Si-100 at 220 volts, you must change the setting of the 110/220V switch before applying power to the Si-100. The Si-100 is factory preset for 110 volts.

Connecting to 110 Volts

The Si-100 is set for 110 volt operation at the factory. All you need to do is an AC power cord and the AC Power connector that comes with the Si-100. If you want to direct wire the Si-100 to AC power, you must consult a qualified electrician and observe all building and electrical codes.

The AC cord you can install yourself, but be careful: AC power can be dangerous.

Connecting to 220 Volts

The Si-100 is set for 110 volt operation at the factory. In order to use 220 volts, you'll need to change a switch setting inside the case. You will need a medium sized phillips screwdriver to remove the cover.

Before you can change the 110/220 volt switch setting, you must remove all the connectors from the Si-100 front panel. Then remove the four screws from the cover, as shown below.

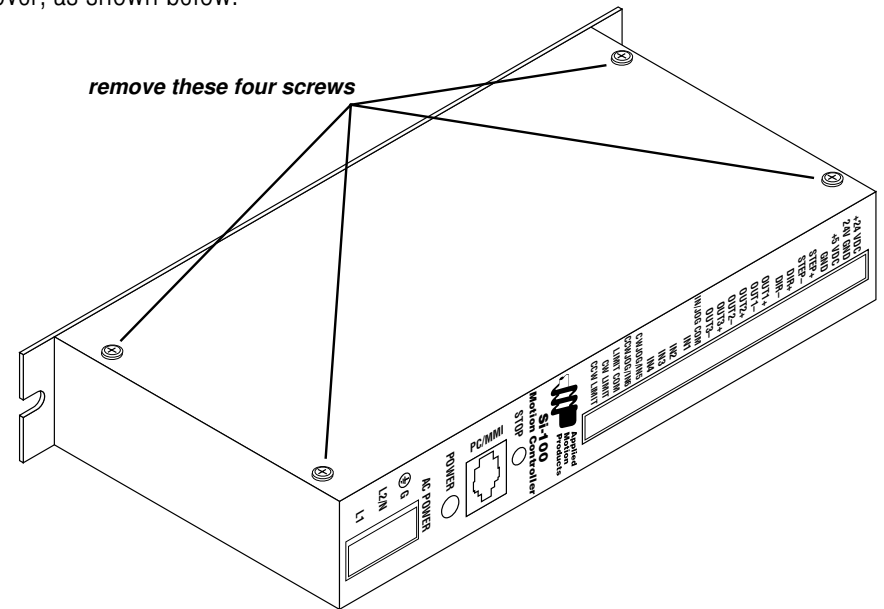

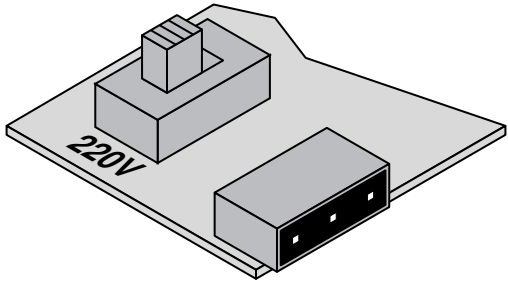

Once you've done that, find the 110/220V switch, which is next to the AC Power connector. Slide the switch toward the label marked "220V", as shown in the sketch. Then replace the cover and secure it with the four screws.

Installing an AC Line Cord

Remove about 5 mm (3/16 inches) of insulation from each of the three wires of your line cord. (That's right, three wires. For safety, always use a three wire power cord on anything with a metal case.) Depending on where you got your power cord, it may have black, white and green wires or brown/blue/green.

The AC power plug that was shipped with your Si-100 might be one of two types. The "old style" is shown below, on the left. The "new style" (shown on the right) comes with an insulating rubber boot.

Make sure you follow the proper sketch for your connector style.

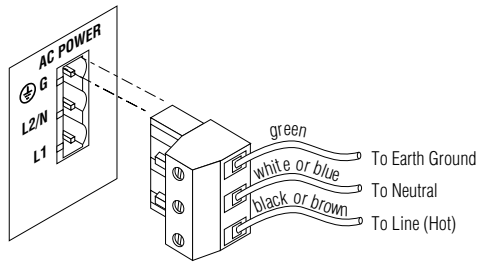

**"Old Style"
AC Power Plug**

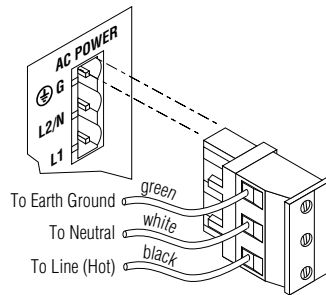

**"New Style"
AC Power Plug**



Always unplug the line cord from the wall before attaching it to the Si-100

- Connect the black or brown wire to the Si-100 "L1" terminal of the AC power connector. That is the line, or "hot" connection.
- Connect the white or blue wire to neutral. That's the "L2/N" terminal.
- Finally, and most importantly, connect the green wire to the GND terminal. That connects the Si-100 metal enclosure and DC power supply ground to earth ground.

Mounting the Si-100

The Si-100 has two mounting slots in the back panel. They're 0.2 inches wide, large enough for number 10 screws. (No screws are included with the Si-100. You'll have to supply your own.)

The Si-100 is not heavy, nor does it generate much heat. Your only concerns for placement should be:

- routing wires to and from the Si-100: keep signal wires away from motor wires and AC power cables
- protecting the Si-100 from anything that might short out the internal circuitry, like water or metal chips.



**Never use your drive in a space where there is no air flow or where the ambient temperature exceeds 70°C.
Never put the drive where it can get wet.
Never allow metal particles near the drive.**

Mounting the Optional MMI

There are two ways to mount the MMI in your application. No matter which method you choose, you'll need to connect the MMI to your Si-100 with the programming cable. You will not, however, need the adapter plug. The MMI has the same telephone style connector as the Si-100.

Depending on how you mount the MMI and cable in your application, you may find that it is difficult to remove the cable from the back of the MMI. If this is the case, and you need to reprogram the Si-100, you can use any telephone line cord as a programming cable. They are available at most supermarkets and discount stores. Please be careful not to lose the adapter plug that connects the telephone cord to the COM port of your PC. The adapter is a custom made part and is only available from Applied Motion.

Microstepping

Most step motor drives offer a choice between full step and half step resolutions. In full step mode, both motor phases are used all the time. Half stepping divides each step into two smaller steps by alternating between both phases on and one phase on.

Microstepping drives precisely control the amount of current in each phase at each step position as a means of electronically subdividing the steps even further. The Si-100 works with full/half step and microstepping drives, and offers a choice of 15 step resolutions. The highest setting divides each full step into 254 microsteps, providing 50,800 steps per revolution when using a 1.8° motor.

In addition to providing precise positioning and smooth motion, microstep drives can be used for motion conversion between different units. The 25,400 step/rev setting is provided as a means of converting motion from metric to english. (There are 25.4 mm in an inch.) Other settings provide step angles that are decimal degrees (36,000 steps/rev makes the motor take 0.01° steps.) Some settings are used with lead screws. When the drive is set to 2000 steps/rev and used with a 5 pitch lead screw, you get .0001 inches/step.

The microstep resolution of the Si-100 is set by the Si Programmer software.

Make sure the step resolution of the Si-100 is the same as the driver it is connected to.

Connecting the Driver

The Si-100 Motion Controller can work with most pulse and direction step motor drivers. Some servo motor drives also accept pulse and direction inputs. Different step motor drivers use different input configurations. There are three basic types that the Si-100 can be used with:

- Differential. Driver has STEP+, STEP-, DIR+ and DIR- inputs. Many high speed microstep drivers use differential inputs.
- Common anode. Driver has STEP and DIR inputs that require sinking signals and a common terminal named "VOPT0" or "+5V"
- Common cathode. Driver inputs are STEP and DIR (requiring sourcing signals) and a common terminal named "common" or "ground."

Wiring diagrams for each type of driver are shown below and on the next page. The first sketch shows the output circuits for the Si-100.

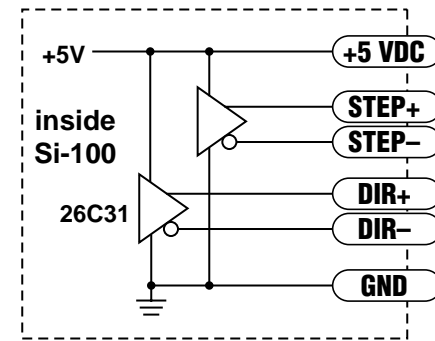

Si-100 Step & Direction Output Circuit

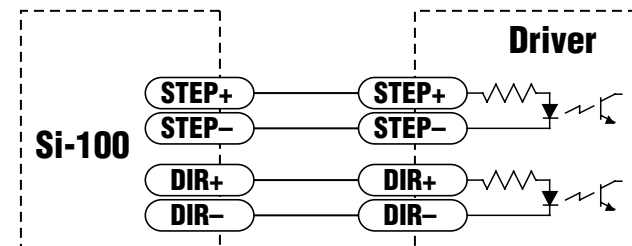

Connecting to a Driver with Differential Inputs
Includes Applied Motion Products models 7080, PD5580 and PD8400.

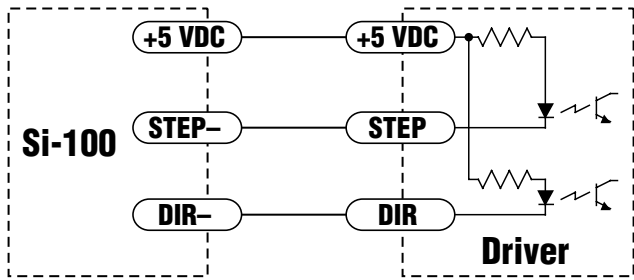

Connecting to a Driver with Common Anode Inputs

Includes Applied Motion models 2035, 3535, 3540M, PD2035, 5560, 1030D

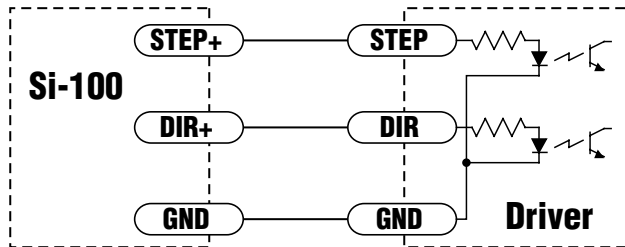

Connecting to a Driver with Common Cathode Inputs

Connecting to the PC

- Locate your computer within 6 feet of the Si-100.
- Your Si-100 was shipped with a black adapter plug. It has a telephone style jack at one end and a larger 9 pin connector at the other. Plug the large end into the COM1 serial port of your PC. Secure the adapter with the screws on the sides. If the COM1 port on your PC is already used by something else, you may use the COM2 port for the Si-100. On some PCs, COM2 will have a 25 pin connector that does not fit the black adapter plug. If this is the case, and you must use COM2, you will have to purchase a 25 to 9 pin serial adapter at your local computer store.
- Your Si-100 was also shipped with a 7 foot telephone line cord. Plug one end into the adapter we just attached to your PC, and the other end into the RS232 jack on your Si-100.

Never connect the Si-100 to a telephone circuit. It uses the same connectors and cords as telephones and modems, but the voltages are not compatible.

Programming Note: Always apply power to Si-100 after the Si™ Programmer software is running on your PC.

Wiring Outputs

Before we discuss the output conditions, we need to talk about the circuitry. All three Si-100 outputs are optically isolated. That means that there is no electrical connection between the indexer-drive and the output terminals. The signal is transmitted to the output as light. What you "see" is a transistor (NPN type) that closes, or conducts current, when the output is "low". When the output is high, the transistor is open.

At power-up, the Si-100 sets all three programmable outputs high (open circuit).

The maximum voltage between any pair of + and - output terminals is 24 volts DC. Never connect AC voltages to the Si-100 output terminals. Maximum current is 100 mA per output.

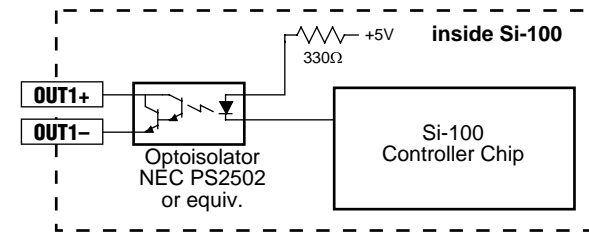

Schematic Diagram of Si-100 Output Circuit

Since there is no electrical connection to the Si-100, you must provide the source of current and voltage, typically from a power supply. You must also limit the current to less than 100 mA so that the output transistor is not damaged. You would normally use a resistor for this, but some loads (such as PLC inputs) limit the current automatically.

The diagram below shows how to connect an Si-100 output to an optically isolated PLC input.

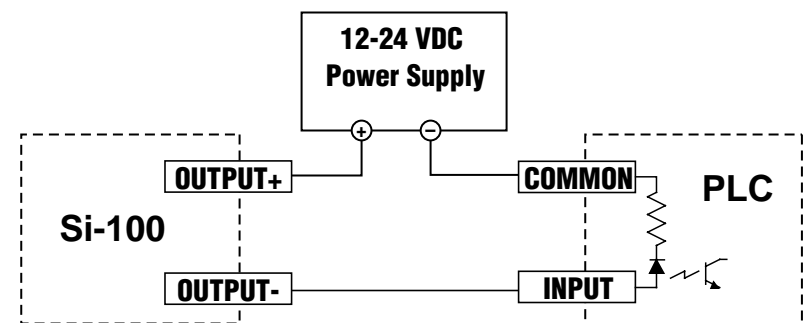

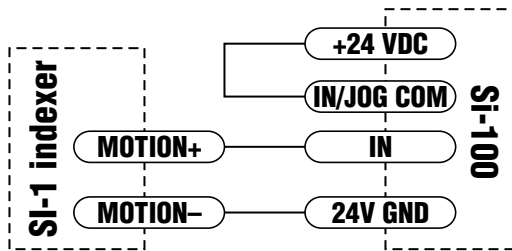

Connecting an Input to the SI-1 Motion Output

(Set SI-1 motion signal to "in position". SI-1 will trigger Si-100 at end of each move.)

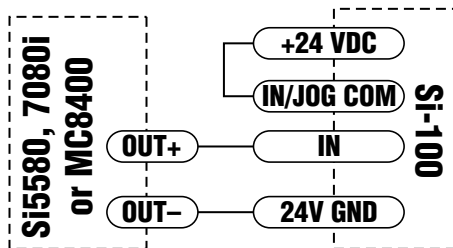

Connecting an Si5580, 7080i or MC8400

(When output closes, Si-100 input goes low.)

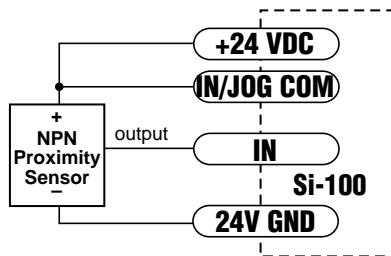

Connecting an NPN Type Proximity Sensor to an Si-100 Input

(When prox sensor activates, Si-100 input goes low.)

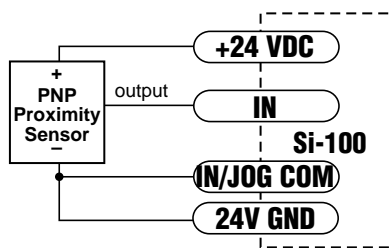

Connecting a PNP Type Proximity Sensor to an Si-100 input

(When prox sensor activates, Si-100 input goes low.)

Front Panel Stop Button

On the front panel of the Si-100 is a button marked "STOP." This button can be used to interrupt motion at any time. After pressing the STOP button, the output pulses to the motor driver will stop. The front panel Power LED will then flash until the AC power is removed from the indexer. If the Si-100 is connected to a PC running the Windows Programming Software, the software will alert the user on screen to the condition, and ask if you want to reset the indexer from the PC.

Jogging

Two of the Si-100 input terminals are provided for jogging the motor. The inputs are labeled "JOG CW" and "JOG CCW". Taking one of the inputs low commands the drive to move the motor at a pre-designated speed until the contact is opened. A relay or mechanical switch can be used to activate the jog inputs. 5 volt circuitry can also be used. The schematic diagram of the input circuit is shown below.

If you're using a switch or relay, wire one end to the JOG input and the other to the 24V GND terminal. Then connect the IN/JOG COM and +24 VDC terminals.

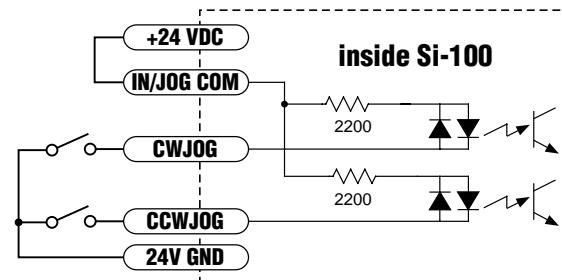

Limit Switches

The Si-100 has two limit switch inputs, LIMIT CW and LIMIT CCW. By connecting switches or sensors that are triggered by the motion of the motor or load, you can force the Si-100 to operate within certain limits. This is useful if a program error could cause damage to your system by traveling too far.

The limit inputs are optically isolated. This allows you to choose a voltage for your limit circuits of 5 to 24 volts DC. It also allows you to have long wires on limit sensors that may be far from the Si-100 with less risk of introducing noise to the Si-100. The schematic diagram of the limit input circuit is shown below.

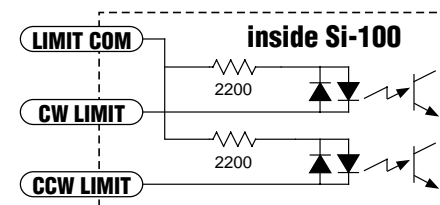

Wiring a Limit Switch

You can use normally open or normally closed limit switches. Either way, wire them as shown here.

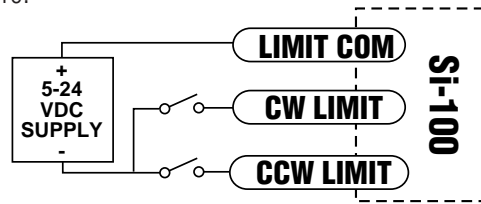

Limit Sensors

Some systems use active limit sensors that produce a voltage output rather than a switch or relay closure. These devices must be wired differently than switches.

If your sensor has an open collector output or a sinking output, wire it like this:

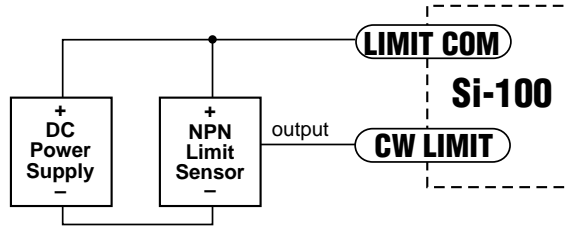

Wiring for Sinking or Open Collector Output

If the sensor output goes low at the limit, select the option "closed." If the output is open, or high voltage, choose "open."

Other sensors have sourcing outputs. That means that current can flow out of the sensor output, but not into it. In that case, wire the sensor this way:

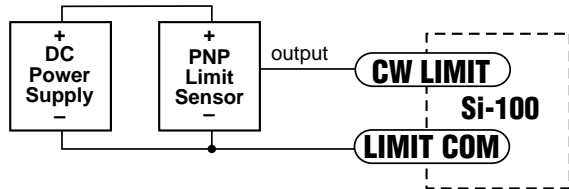

Wiring for Sourcing Output

If the sensor output goes high at the limit, choose the program option "closed." If the output is low at the limit, select "open."

Wiring Inputs

The Si-100 input circuits can be used with sourcing or sinking signals, 5 to 24 volts. This allows connection to TTL circuits, PLCs, relays and mechanical switches. Because the input circuits are isolated, they require a source of power. If you are connecting to a TTL circuit or to a PLC, you should be able to get power from the PLC or TTL power supply. If you are using relays or mechanical switches, you can use the Si-100's built-in 24 volt power supply. This also applies if you are connecting the Si-100 inputs to another SI product from Applied Motion, like the SI-1 indexer or the Si5580, 7080i and MC8400 indexer-drives.

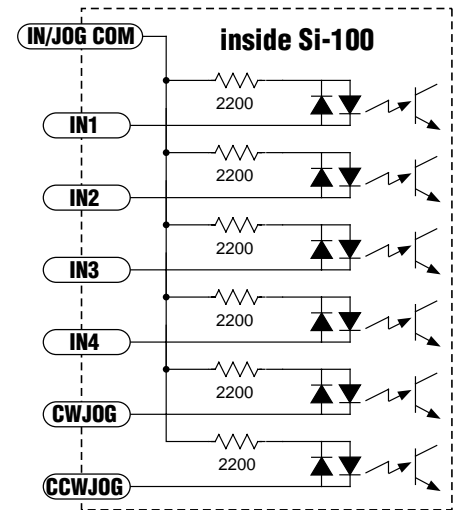

Note: if current is flowing into or out of an Si-100 input, the logic state of that input is low. If no current is flowing, or the input is not connected, the logic state is high.

The diagrams on the following pages show how to connect Si-100 inputs to various devices.

The maximum voltage that can be applied to an input terminal is 24 volts DC. Never apply AC voltage to an input terminal.

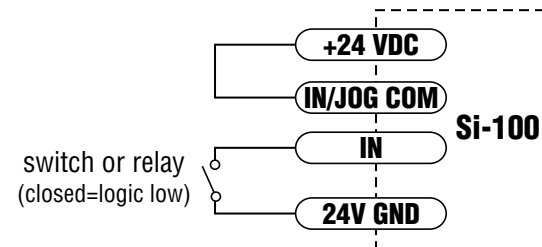

Connecting an Input to a Switch or Relay

Use normally open momentary switch to trigger Si-100 using Wait Input instruction.

Use single throw switch for parameter selection using If Input instruction.

Use normally open momentary switch for jogging.