

10/15/03  
1035man.ai

# User's Manual

## 1035D

### 2 Axis Step Motor Driver

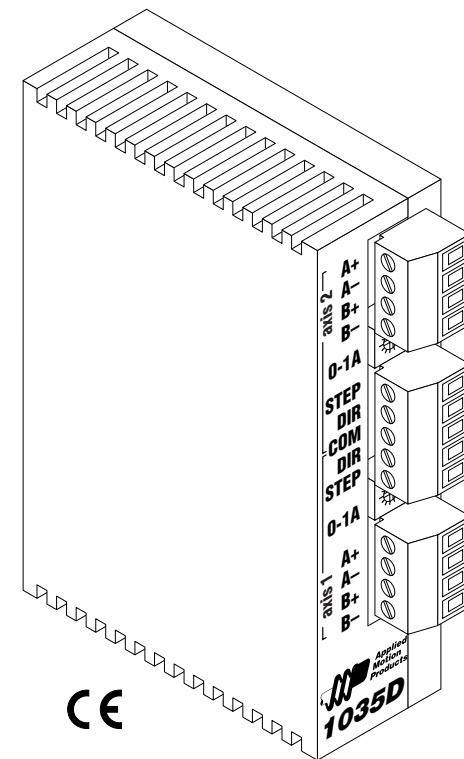

Copyright 2003

**Applied Motion Products, Inc.**

404 Westridge Drive Watsonville, CA 95076

Tel (831) 761-6555 (800) 525-1609 Fax (831) 761-6544

**Applied  
Motion  
Products**  
motors • drives • controls



## Technical Specifications

- Amplifiers** Dual, bipolar H-bridge, pulse width modulated switching at 20kHz. 12-35 VDC input. 0 - 1.0 amp/phase output current, adjusted by trimpot. 35 watts maximum output power per axis. Automatic idle current reduction, reduces current to 50% of setting after one half second.
- Inputs** Step and direction, optically isolated, 5-24V logic. Can be configured for sinking or sourcing signals. 2200 ohms input impedance. Motor steps on rising edge of step line. 10  $\mu$ sec minimum low pulse. 50  $\mu$ sec minimum set up time for direction signal.
- Physical** Housed in molded plastic case. Mounts on EN50022 (35 mm) DIN rail. Can also be attached to Aromat (NAiS) FPO PLC. 1.0 x 2.4 x 3.55 inches overall. See page 13 for detailed drawing. Weight: 9 ounces (250 g). Ambient temp range (operating): 0 - 70°C.
- Connectors** European style screw terminal blocks. Motors: 4 position. Signal Input: 5 position. DC Input: 2 position. Wire size: AWG 16-28.
- CE Mark** Complies with EN55011A and EN50082-1(1992).



## Introduction

Thank you for selecting an Applied Motion Products motor control. We hope our dedication to performance, quality and economy will make your motion control project successful.

If there's anything we can do to improve our products or help you use them better, please call or fax. We'd like to hear from you. Our phone number is (800) 525-1609 or you can reach us by fax at (831) 761-6544.

You can also find useful information 24 hours a day at our web site: [www.applied-motion.com](http://www.applied-motion.com).

## Features

- Drives two step motors independently.
- Drives NEMA motor sizes 14 through 23.
- Pulse width modulation switching amplifiers.
- Phase current from 0 to 1.0 amps (each axis independently adjustable by trimpot.)
- Step and direction inputs, optically isolated, 5-24V logic.
- Full and half step (jumper selectable)
- Automatic 50% idle current reduction

## Block Diagram

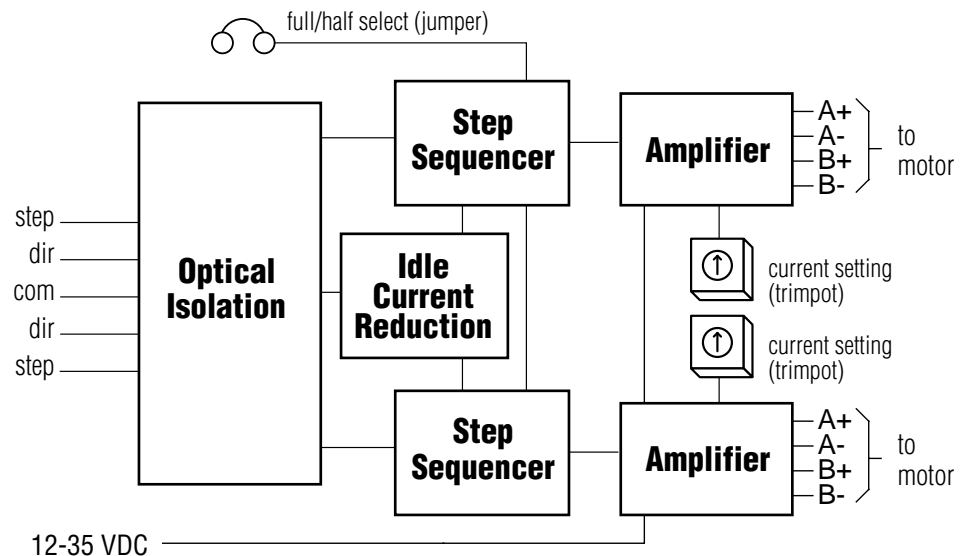

## Getting Started

To use your Applied Motion Products motor control, you will need the following:

- a 12-35 volt DC power supply for the motor. Please read the section *Choosing a Power Supply* for help in choosing the right power supply.
- a source of step & direction signals (indexer, oscillator or PLC).
- a source of power to activate the optoisolation circuits. Many indexers & PLCs have power available for this purpose. If not, you may need a small 5 - 24 VDC power supply.
- a small flat blade screwdriver (0.1" wide) for tightening the connectors and setting the current.

The sketch below shows where to find the important connection and adjustment points. Please examine it now.

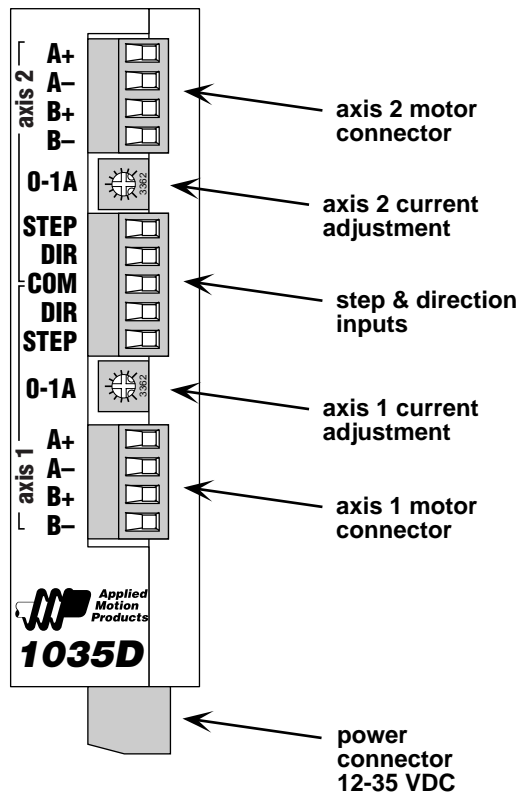

## Mechanical Outline

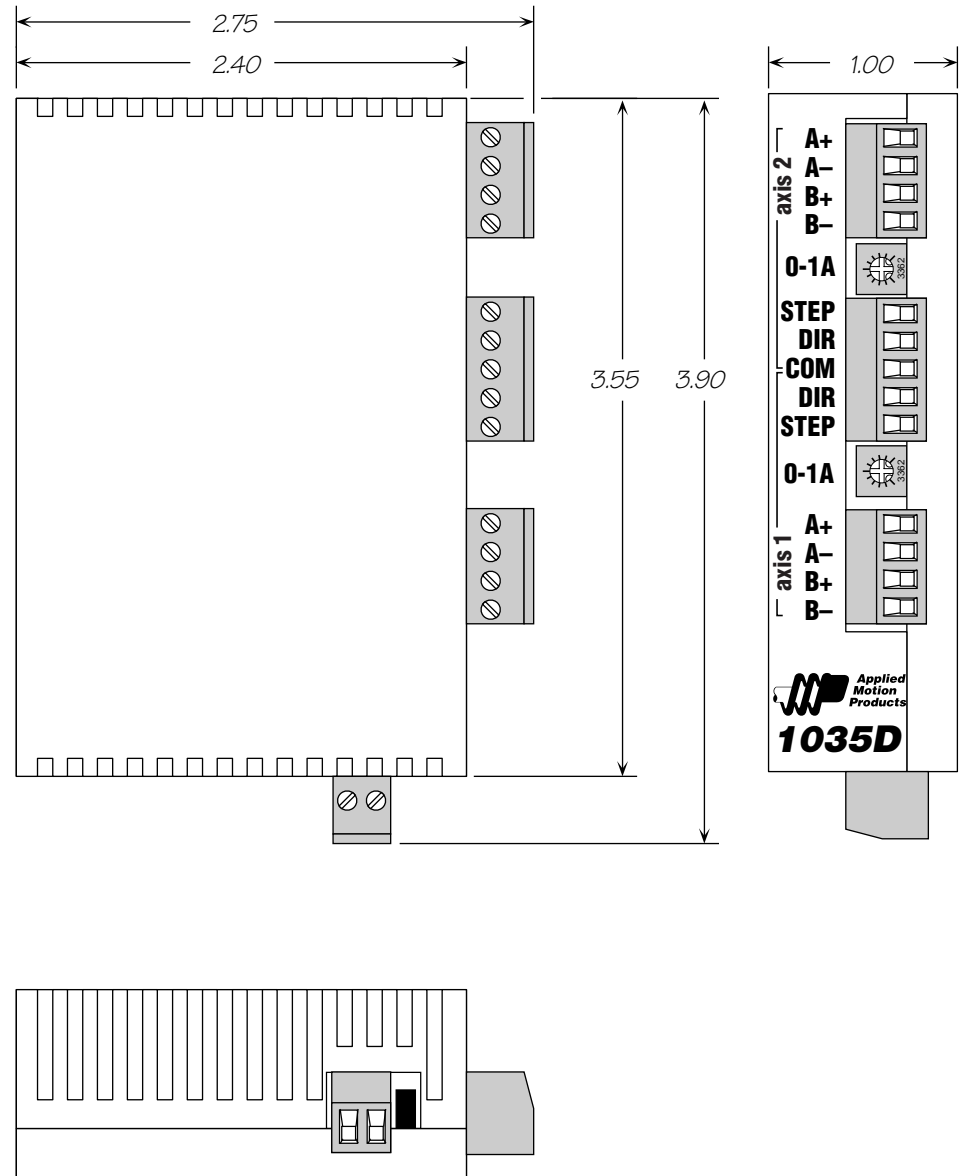

## Mounting the Drive

The 1035D is designed for DIN rail mounting. First, secure a piece of 35mm (EN50022) DIN rail to a rigid surface. Normally, that would be the wall of a wiring cabinet. Then hang the 1035D on the DIN rail and press the blue plastic tab to lock the drive to the rail.

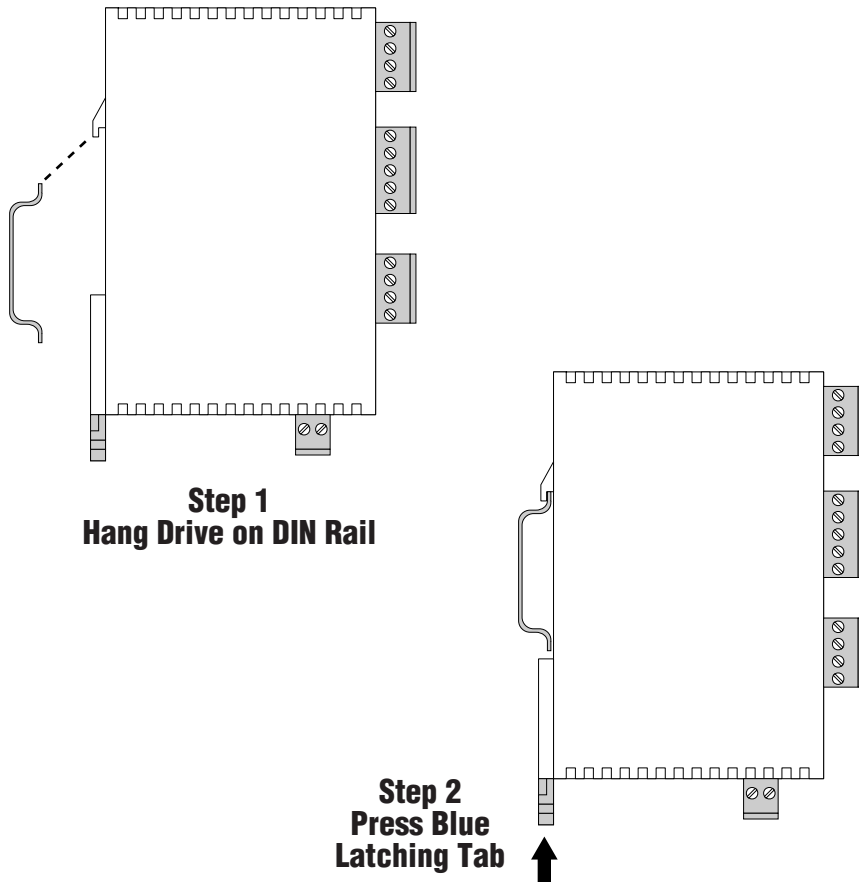

The amplifiers and voltage regulator in the 1035D have been specially designed for maximum efficiency. Still, they generate some heat, which must leave the 1035D through the slots in the case.

**Never use your drive where there is no air flow.**  
**Always mount the drive vertically.**  
**Never block the ventilation slots.**  
**Never put the drive where it can get wet or where metal particles can get on it.**

## Connecting the Power Supply

If you need information about choosing a power supply, please read *Choosing a Power Supply* located in the back of this manual.

If your power supply does not have a fuse on the output or some kind of short circuit current limiting feature you need to put a 2 amp slow blow fuse between the drive and power supply. Install the fuse on the **positive** power supply lead.

Connect the motor power supply **positive** terminal to the driver terminal marked "+". Connect power supply **return** to the drive terminal marked "-". Use no smaller than 20 gauge wire. **Be careful not to reverse the wires.** Reverse connection will destroy your driver, void your warranty and generally wreck your day.

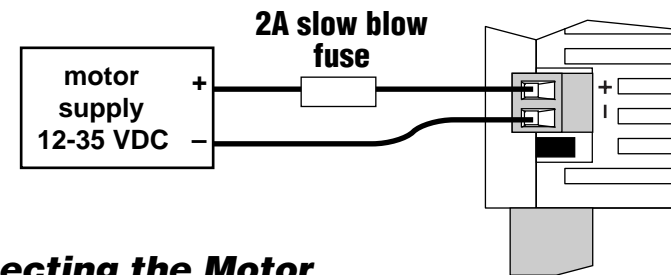

## Connecting the Motor

**Warning:** When connecting the motor to the driver, be sure that the motor power supply is off. Secure any unused motor leads so that they can't short out to anything. Never disconnect the motor while the drive is powered up. Never connect motor leads to ground or to a power supply!

You must now decide how to connect your motor to the drive.

**Four lead motors** can only be connected one way. Please follow the sketch at the right.

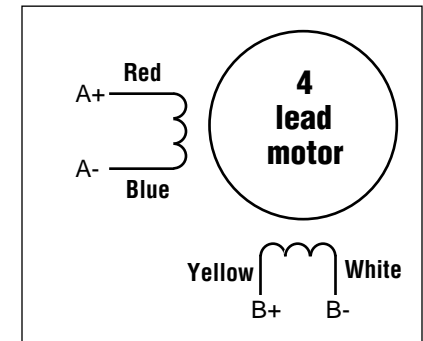

4 Leads

**Six lead motors** can be connected in series or center tap. In series mode, motors produce more torque at low speeds, but cannot run as fast as in the center tap configuration. In series operation, the motor should be operated at 30% less than the rated current to prevent overheating. Winding diagrams for both connection methods are shown on the next page

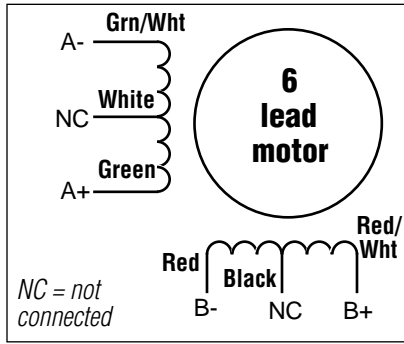

6 Leads Series Connected

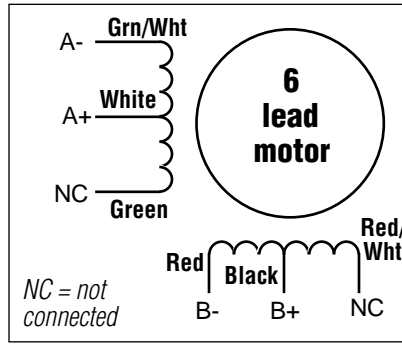

6 Leads Center Tap Connected

**Eight lead motors** can also be connected in two ways: series and parallel. As with six lead motors, series operation gives you more torque at low speeds and less torque at high speeds. In series operation, the motor should be operated at 30% less than the rated current to prevent over heating. The wiring diagrams for eight lead motors are shown below.

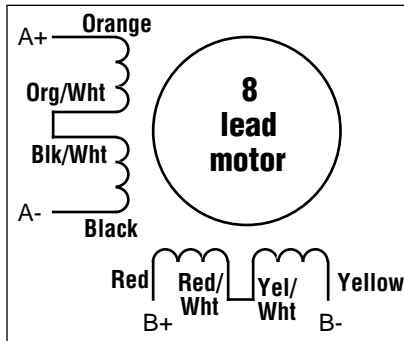

8 Leads Series Connected

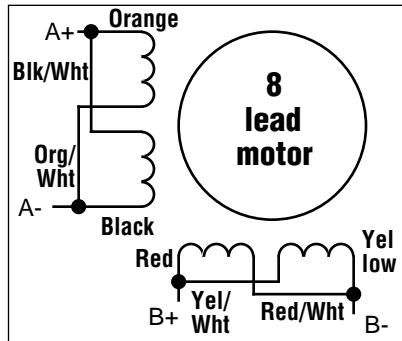

8 Leads Parallel Connected

Step Table  
(full stepping)

Step	A+	A-	B+	B-
0	+	-	+	-
1	-	+	+	-
2	-	+	-	+
3	+	-	-	+
4	+	-	+	-

Step 3 is the Power Up State

## Choosing a Power Supply

### Voltage

Chopper drives work by switching the voltage to the motor terminals on and off while monitoring current to achieve a precise level of phase current. To do this efficiently and silently, you'll want to have a power supply with a voltage rating at least five times that of the motor. Depending on how fast you want to run the motor, you may need even more voltage than that. More is better, the only upper limit being the maximum voltage rating of the drive itself: 35 volts. If you choose an unregulated power supply, do not exceed 24 volts. This is because unregulated supplies are rated at full load current. At lesser loads, like when the motor's not moving, the actual voltage can be up to 1.4 times the rated voltage.

### Current

The maximum supply current you will need is the sum of the two phase currents. (Four phase currents if you are using two motors.) However, you will generally need a lot less than that, depending on the motor type, voltage, speed and load conditions. That's because the 1035D uses switching amplifiers, converting a high voltage and low current into lower voltage and higher current. The more the power supply voltage exceeds the motor voltage, the less current you'll need from the power supply.

We recommend the following selection procedure:

1. If you plan to use only a few drives, get a power supply with at least twice the rated phase current of the motor. If you are using two motors with the 1035D (after all, that's why you bought a two axis drive) then you should double the rated current of each motor and add them together.

2. If you are designing for mass production and must minimize cost, get one power supply with more than four times the rated current of the motors. Install the motor in the application and monitor the current coming out of the power supply and into the drive at various motor loads. This will tell you how much current you really need so you can design in a lower cost power supply.

If you plan to use a regulated power supply you may encounter a problem with current foldback. When you first power up your drive, the full current of all motor phases will be drawn for a few milliseconds while the stator fields are being established. After that the amplifiers start chopping and much less current is drawn from the power supply. If your power supply thinks this initial surge is a short circuit it may "foldback" to a lower voltage. With many foldback schemes the voltage returns to normal only after the first motor step and is fine thereafter. In that sense, unregulated power supplies are better. They are also less expensive.

## Recommended Motors

The following motors from Applied Motion Products are recommended for use with the 1035D. All motors in the list have been tested with the 1035D. Dynamic torque data is available.

Motor Number	Size inches	Winding Connection	Max Torque oz-in	Current Amps
5014-842	1.38 x 1.38 x 1.57	4 lead	22	1.0
5017-006	1.65 x 1.65 x 1.34	center-end	10	1.0
5017-009	1.65 x 1.65 x 1.54	center-end	17	0.8
5017-013	1.65 x 1.65 x 1.85	center-end	24	0.8
HT17-068	1.65 x 1.65 x 1.30	parallel	22	1.0
HT17-072	1.65 x 1.65 x 1.54	parallel	34	1.0
HT17-076	1.65 x 1.65 x 1.85	parallel	54	1.0
4023-839	2.22 x 2.22 x 1.5	center-end	35	1.0
4023-819	2.22 x 2.22 x 2.0	center-end	56	1.0
HT23-393	2.22 x 2.22 x 1.54	parallel	34	1.0
HT23-396	2.22 x 2.22 x 2.13	parallel	110	1.0
HT23-399	2.22 x 2.22 x 2.99	parallel	140	1.0

## Connecting A Pulse Source

The 1035D inputs contain optical isolation circuitry to prevent the electrical noise inherent in switching amplifiers from interfering with your circuits.

Optical isolation also allows the 1035D to accept step and direction signals ranging from 5 to 24 volts. Furthermore, the input signals can be sourcing (PNP) or sinking (NPN), depending on how you connect the COM terminal.

A schematic diagram of the input circuit is at the right. The wiring diagrams below show how to connect the drive to various pulse sources.

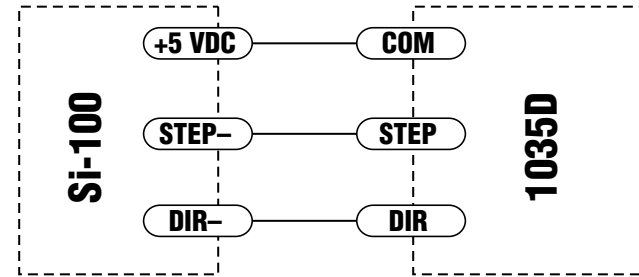
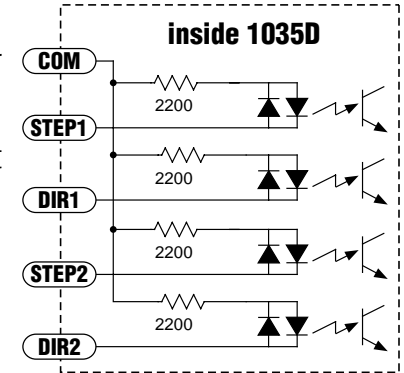

Connecting Applied Motion Si-100

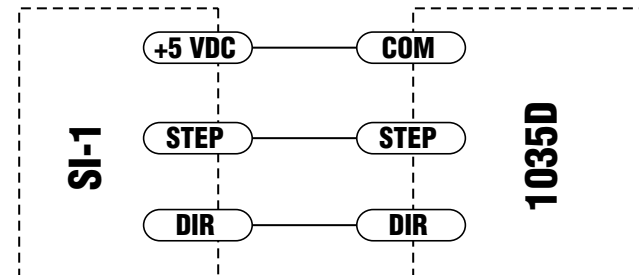

Connecting Applied Motion SI-1

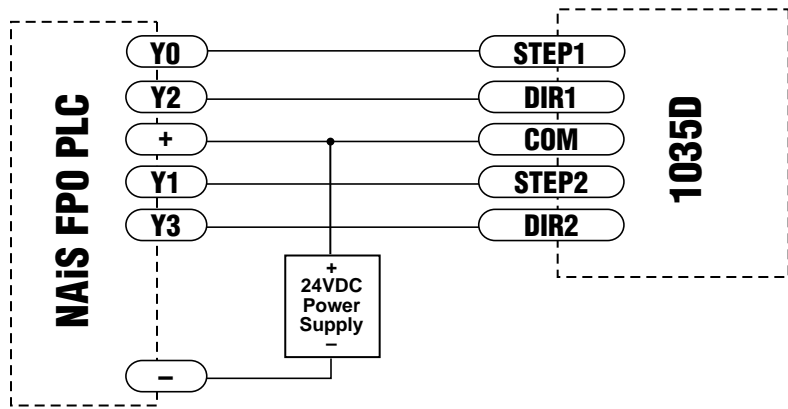

**Connecting Aromat (NAiS) Model FPO PLC**

### Selecting Between Full and Half Step Operation

The 1035D is shipped from the factory in full step mode. This results in more torque at low speeds than half step mode. Full stepping also allows you to achieve higher speeds than half stepping if the speed of your pulse source is limited. For example, to drive a motor at 25 rev/sec in half step mode, you must supply step pulses to the 1035D at a rate of 10,000 Hz. To get 25 rev/sec in full step mode, only 5,000 pulses/sec are required.

*Half stepping is smoother and quieter than full step, so you should use half step mode whenever possible.*

To change a 1035D to half step operation, remove the black jumper located next to the power supply connector. You may need a pair of small pliers, tweezers, or someone with sharp fingernails to remove the jumper. *Removing the jumper sets both axes to half step mode.*

Custom software is also available for 1/4 stepping, which provides more precise positioning and smoother motion than full and half stepping.

**For special options please call the factory.**

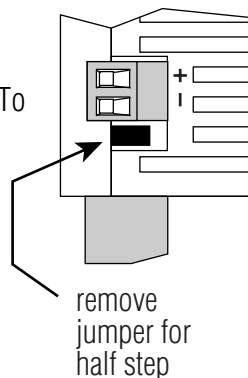

### Setting Phase Current

Before you turn on the power supply the first time, you need to set the driver for the proper motor phase current. The rated current is usually printed on the motor label. For a list of recommended Applied Motion Products motors and their rated current, see page 10.

The current for each axis is set independently by trimpots located on the front panel of the 1035D. The sketch below shows how to set the trimpots.

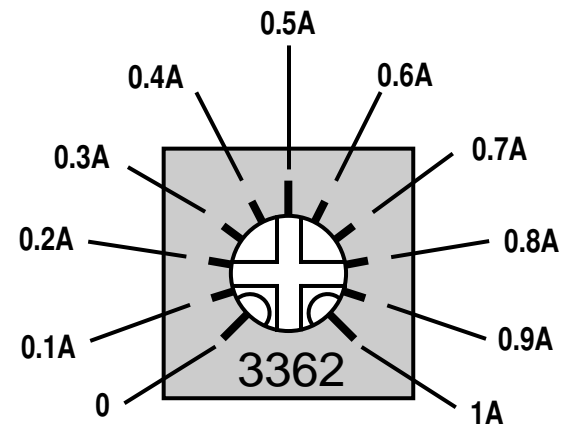

**1035D current setting**  
(shown at 0.5A)

### Idle Current Reduction

The 1035D includes a feature that automatically reduces the motor current by 50% when the motor is not moving. This is known as idle current reduction.

The idle current reduction is not adjustable by the user. However, for qualifying OEMs, we can change the amount of current reduction during the manufacturing process. This is accomplished by changing the software in the sequencing chips. These chips are socketed, so units can be retrofitted if necessary.

**For special options please call the factory.**