

REVISIONS			
REV	DESCRIPTION	DATE	APPROVED
A	INITIAL RELEASE ECO 6994	5/22/14	J KORDIK
B	ADD LABEL ECO 7060	9/15/14	J KORDIK
C	REVISE SPEC PER ECO 7205	5/8/15	J Kordik
D	ADD UL TO LABEL PER ECO 7330	10/12/15	J KORDIK
E	SPECS REVISED PER ECO 7510	10/12/15	J KORDIK

**ENCODER CONNECTOR**  
CONNECTOR: AMP 172171-1  
770835-1 contacts (strip)  
VIEWING MATING END

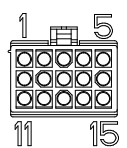

**MOTOR POWER CONNECTOR**  
CONNECTOR: AMP 172167-1  
170360-1 contacts (strip)  
VIEWING MATING END

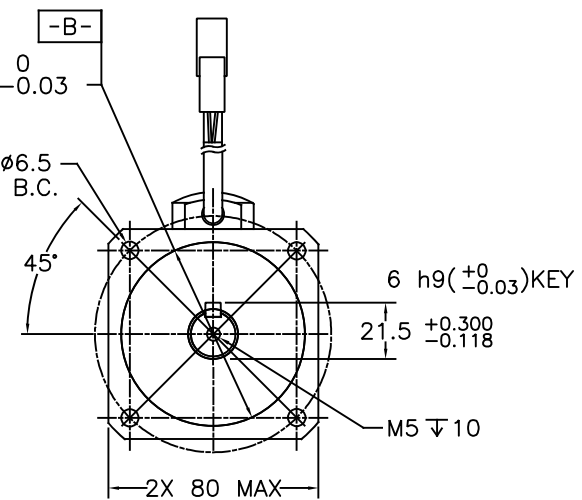
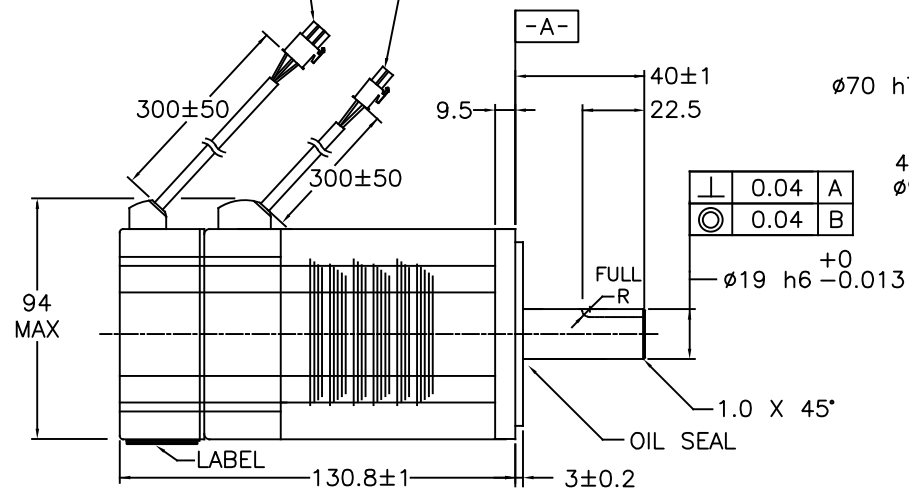
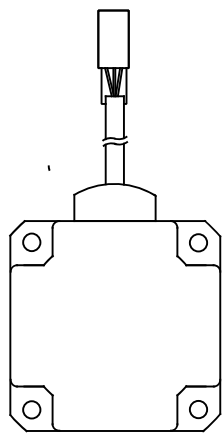
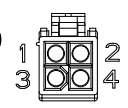

⊥	0.04	A
⊙	0.04	B

Ø19 h6 -0.013

ENCODER CONNECTION TABLE		
PIN	LEAD COLOR	SIGNAL
1	RED	+5V
2	BLACK	GROUND
3	BROWN	U+
4	BROWN/BLACK	U-
5	GRAY	V+
6	GRAY/BLACK	V-
7	WHITE	W+
8	WHITE/BLACK	W-
9	BLUE/BLACK	A+
10	BLUE	A-
11	GREEN	B+
12	GREEN/BLACK	B-
13	YELLOW	Z+
14	YELLOW/BLACK	Z-
15	SHIELD	SHIELD

MOTOR CONNECTION TABLE		
PIN	LEAD COLOR	SIGNAL
1	RED	PHASE U
2	YELLOW	PHASE V
3	BLUE	PHASE W
4	YELLOW/GREEN	GROUND

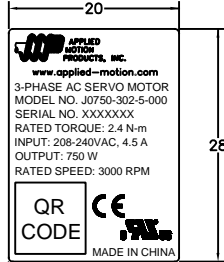

R 1.5  
4PLCS

- NOTES: UNLESS OTHERWISE SPECIFIED
1. A SHAFT SEAL IS SHIPPED WITH MOTOR, BUT NOT INSTALLED.
  2. TIMING LOGIC IS CCW AS VIEWED FROM FRONT SHAFT.
  3. MOTOR IS IP65, EXCEPT SHAFT OPENING AND CABLE CONNECTOR.
  4. INSTALL INDOORS, AWAY FROM DIRECT SUNLIGHT AND FLAMMABLE GASES.
  5. 1000M MAX ALTITUDE.

TOLERANCES	THIRD ANGLE PROJECTION
DECIMALS: MM (INCH) X.XXX = ±0.013 (.005) X.XX = ±0.25 (.01) X.X = ±2.5 (0.1)	
APPROVALS	DATE
DRAWN R.JONEZ	5/19/14
CHECKED	
APPROVED	
COMPUTER DATA BASE DRAWING	

**APPLIED MOTION PRODUCTS, INC.**

**AC SERVO MOTOR**

B DWG NO. J0750-302-5-000 REV E

SCALE: NONE SHEET 1 OF 2

AC SERVOMOTOR SPECIFICATION – PERMANENT MAGNET 8 POLES		
INPUT POWER SUPPLY	VAC	208–240 1/3 PHASE
RATED OUTPUT	W	750
VOLTAGE CONSTANT	V(rms)/K(rpm)±10%	36.6
RATED WINDING CURRENT	A (rms)	4.5
PEAK WINDING CURRENT	A (rms)	13.5
WINDING RESISTANCE	V ±10%@20°C	1.47 LINE-TO-LINE
WINDING INDUCTANCE	mH ±20%	8.2 LINE-TO-LINE
RATED TORQUE	Nm(kgf-cm)	2.4(24.47)
PEAK TORQUE	Nm(kgf-cm)	6.9(70.36)
TORQUE CONSTANT	Nm/A(rms)±10%	0.543
RATED SPEED	rpm/min	3000
MAXIMUM SPEED	rpm/min	5500
WEIGHT	KG (LBS)	2.6(5.8)
INSULATION CLASS		B 130°C
ENCODER RESOLUTION		2500 LINES/REV.
SHAFT LOAD – AXIAL	N(MAX)	90 N/20LB
SHAFT LOAD – RADIAL	N(MAX)	270 N/60LB
MOTOR RATING	REF NOTE 3	IP65
AMBIENT TEMPERATURE	OPERATING	0 TO 40°C
AMBIENT TEMPERATURE	STORAGE	-20 TO 80°C
AMBIENT HUMIDITY MAX		85%
INERTIA – WITH ENCODER	kg m <sup>2</sup>	0.000089

**TIMING LOGIC / ENCODER SIGNALS**  
(NOT TO SAME SCALE AS OTHER DETAIL)

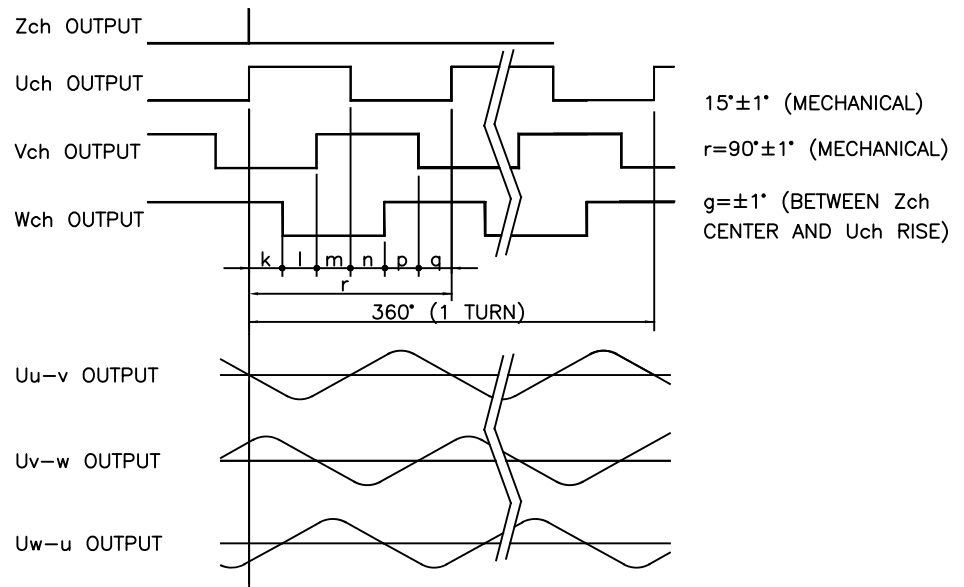

**TIMING LOGIC / ENCODER SIGNALS**

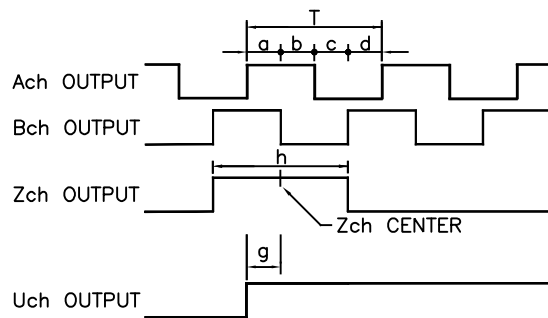

$$T = \frac{360 \text{ DEGREES}}{2500C/T}$$

$$a, b, c, d = T/4 \pm T/8$$

$$h = T \pm T/2$$

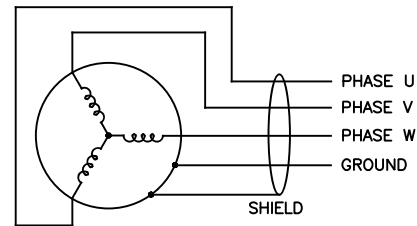

CONTRACT NO.		 <b>APPLIED MOTION PRODUCTS, INC.</b>			
APPROVALS	DATE				
DRAWN <b>R. JONEZ</b>	<b>5/19/14</b>	<b>SERVO MOTOR SPECIFICATIONS</b>			
CHECKED					
APPROVED		<b>B</b>	FSCM NO.	DWG NO. <b>J0750-302-5-000</b>	REV <b>E</b>
APPROVED		SCALE: NONE			SHEET 2 OF 2