

REVISIONS			
REV	DESCRIPTION	DATE	APPROVED
A	INITIAL RELEASE ECO 7060	9/15/14	J KORDIK
B	REVISE TEXT ECO 7159	3/16/15	J KORDIK
C	REVISE SPEC PER ECO 7205	5/8/15	J Kordik
D	ADD UL TO LABEL PER ECO 7330	10/12/15	J Kordik
E	SPECS REVISED PER ECO 7510	10/20/16	J Kordik

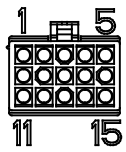

ENCODER CONNECTOR
CONNECTOR: AMP 172171-1
770835-1 contacts (strip)
VIEWING MATING END

BRAKE CONNECTOR

CONNECTOR: AMP 172165-1
170360-1 contacts (strip)
VIEWING MATING END



MOTOR POWER CONNECTOR

CONNECTOR: AMP 172167-1
170360-1 contacts (strip)
VIEWING MATING END

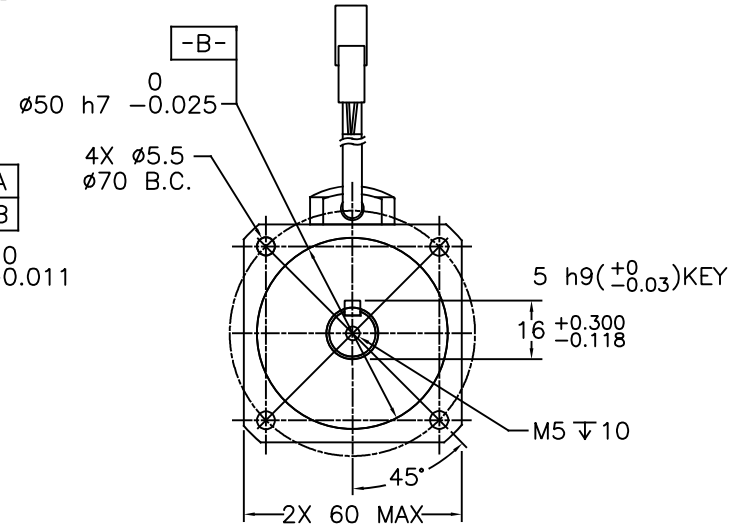
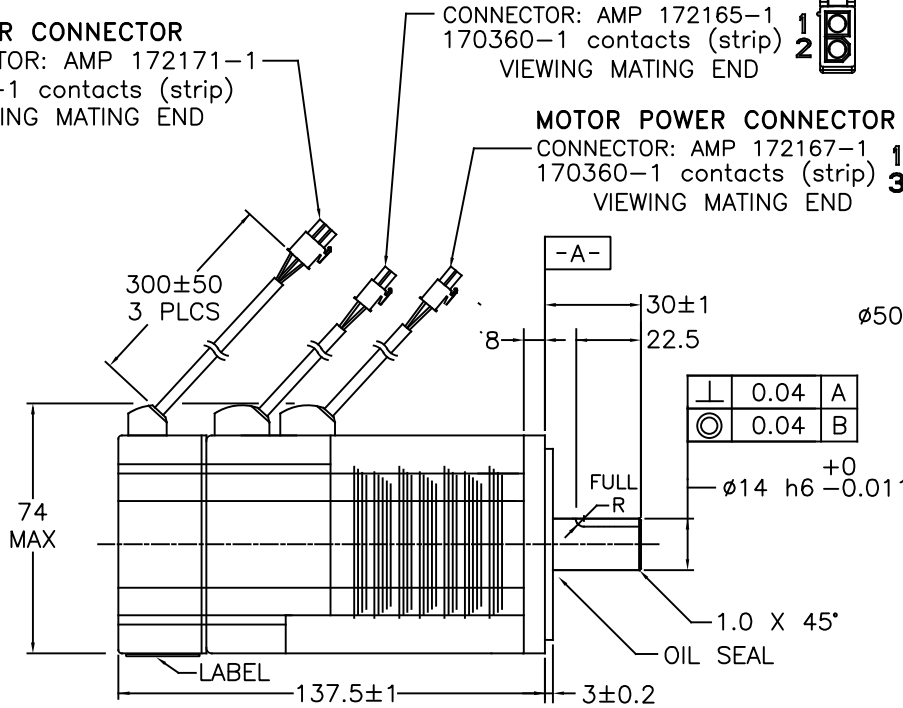
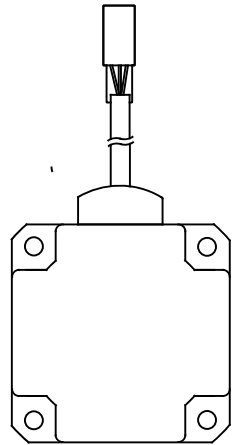

ENCODER CONNECTION TABLE		
PIN	LEAD COLOR	SIGNAL
1	RED	+5V
2	BLACK	GROUND
3	BROWN	U+
4	BROWN/BLACK	U-
5	GRAY	V+
6	GRAY/BLACK	V-
7	WHITE	W+
8	WHITE/BLACK	W-
9	BLUE/BLACK	A+
10	BLUE	A-
11	GREEN	B+
12	GREEN/BLACK	B-
13	YELLOW	Z+
14	YELLOW/BLACK	Z-
15	SHIELD	SHIELD

MOTOR CONNECTION TABLE		
PIN	LEAD COLOR	SIGNAL
1	RED	PHASE U
2	YELLOW	PHASE V
3	BLUE	PHASE W
4	YELLOW/GREEN	GROUND

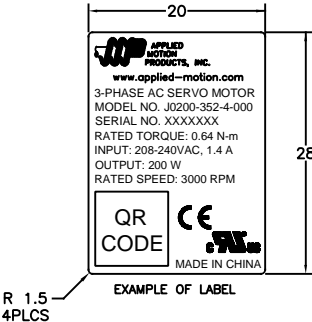

R 1.5
4PLCS

BRAKE CONNECTION TABLE		
PIN	LEAD COLOR	SIGNAL
1	RED	BRAKE
2	BLACK	BRAKE

- NOTES: UNLESS OTHERWISE SPECIFIED
1. A SHAFT SEAL IS SHIPPED WITH MOTOR, BUT NOT INSTALLED.
 2. TIMING LOGIC IS CCW AS VIEWED FROM FRONT SHAFT.
 3. MOTOR IS IP65, EXCEPT SHAFT OPENING AND CABLE CONNECTOR.
 4. INSTALL INDOORS, AWAY FROM DIRECT SUNLIGHT, FLAMMABLE AND CORROSIVE GASES.
 5. 1000M MAX ALTITUDE.
 6. BRAKE RELEASES WHILE ENERGIZED, DO NOT ENGAGE WHILE MOTOR IS ROTATING. BRAKE POWER IS NOT POLARITY SENSITIVE. THIS IS A HOLDING BRAKE.

TOLERANCES	THIRD ANGLE PROJECTION
DECIMALS: MM (INCH) X.XXX = ±0.013 (.005) X.XX = ±0.25 (.01) X.X = ±2.5 (0.1)	
ANGLES: MACH. = ±5° CHAM. = ±5°	APPROVALS DRAWN R.JONEZ CHECKED APPROVED
COMPUTER DATA BASE DRAWING	DATE 5/22/14

APPLIED MOTION PRODUCTS, INC.

AC SERVO MOTOR WITH ENCODER AND BRAKE

DWG NO. **J0200-352-4-000** REV **E**

SCALE: NONE SHEET 1 OF 2

AC SERVO MOTOR SPECIFICATION – PERMANENT MAGNET 8 POLES		
INPUT POWER SUPPLY	VAC	208–240 1/3 PHASE
RATED OUTPUT	W	200
VOLTAGE CONSTANT	V(rms)/K(rpm)±10%	27.2
RATED WINDING CURRENT	A (rms)	1.5
PEAK WINDING CURRENT	A (rms)	4.5
WINDING RESISTANCE	V ±10%@20°C	8.6 LINE-TO-LINE
WINDING INDUCTANCE	mH ±20%	25 LINE-TO-LINE
RATED TORQUE	Nm(kgf-cm)	0.64(6.53)
PEAK TORQUE	Nm(kgf-cm)	1.9(19.37)
TORQUE CONSTANT	Nm/A(rms)±10%	0.432
RATED SPEED	rpm/min	3000
MAXIMUM SPEED	rpm/min	6000
WEIGHT	Kg (lbs)	1.6(3.5)
INSULATION CLASS		B 130°C
ENCODER RESOLUTION		2500 LINES/REV.
SHAFT LOAD – AXIAL	N MAX(lbs)	70(15)
SHAFT LOAD – RADIAL	N MAX(lbs)	200(45)
MOTOR RATING	REF NOTE 3	IP65
AMBIENT TEMPERATURE	OPERATING	0 TO 40°C
AMBIENT TEMPERATURE	STORAGE	-20 TO 80°C
AMBIENT HUMIDITY MAX		85%
INERTIA – W/ ENC, BRAKE	kg*m ²	0.22 X 10 ⁻⁴

6] BRAKE SPECIFICATIONS:

RATED VOLTAGE	24VDC
RATED CURRENT	0.38A
RELEASE VOLTAGE	18.5 VDC MAX (at 20°C)
STATIC FRICTION TORQUE	2 Nm
ENGAGE TIME	AT NOMINAL AIR GAP (@20°C) <25ms (NEW) FULL RANGE MAX AIR GAP <100ms (WORST COND)
RELEASE TIME	WITHOUT DIODE: <25ms (E-STOP) WITH DIODE: <200ms (NORMAL STOP)

TIMING LOGIC / ENCODER SIGNALS

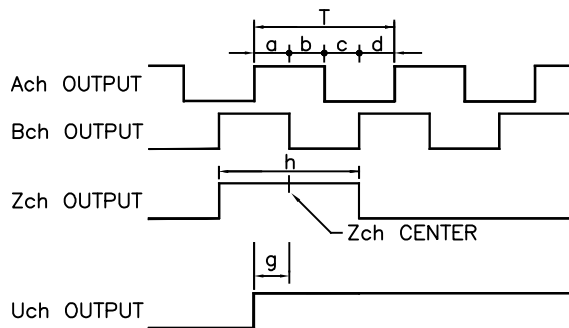

$$T = \frac{360 \text{ DEGREES}}{2500C/T}$$

$$a, b, c, d = T/4 \pm T/8$$

$$h = T \pm T/2$$

TIMING LOGIC / ENCODER SIGNALS
(NOT TO SAME SCALE AS OTHER DETAIL)

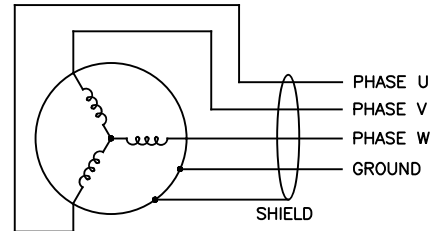
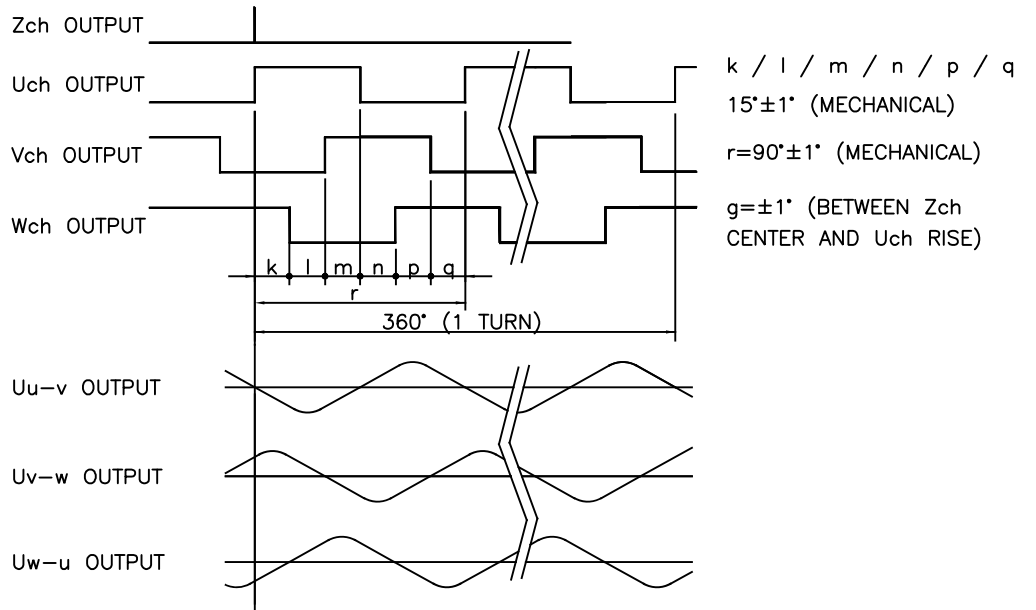

CONTRACT NO.					
APPROVALS	DATE				
DRAWN	<i>R. JONEZ</i>	SERVO MOTOR SPECIFICATIONS			
CHECKED	<i>5/19/14</i>				
APPROVED		B	FSCM NO.	DWG NO.	REV
APPROVED				J0200-352-4-000	E
SCALE: NONE				SHEET 2 OF 2	