

SPECIFICATIONS:	
STEPS PER REVOLUTION: 200	ROTOR INERTIA: 280 G-CM ² (1.53 OZ-IN ²) NOM
STEP ANGLE: 1.8°	HOLDING TORQUE: 8.5 KG-CM (118 OZ-IN)MIN [1]
STEP TO STEP ACCURACY: ± 5 % [1], [2]	DETENT TORQUE: N/A G-CM (N/A OZ-IN)
POSITIONAL ACCURACY: ± 5 % [1], [3]	
HYSTERESIS: %	INSULATION CLASS: B
WINDING RESISTANCE: 1.8 OHM ±10% AT 25° [7]	BEARINGS: ABEC 3, DOUBLE SHIELDED
WINDING INDUCTANCE: 3.2 mH ± 20% [8]	WEIGHT: 0.7 KG (1.54 LB)
PHASE VOLTAGE: 3.6 VDC	TEMP. RISE: 80 °C MAX. [9]
PHASE CURRENT: 2.0 AMP [(RATED)UNIPOLAR] [15]	OPERATING TEMP. RANGE: -20 TO +50°C
	STORAGE TEMP. RANGE: -40 TO 70°C
SHAFT RUNOUT: 0.05 T.I.R.	RELATIVE HUMIDITY RANGE: 5 TO 95 %
RADIAL PLAY: 0.02 MAX W/0.45 KG RADIAL LOAD	
END PLAY: 0.08 MAX W/0.45 KG AXIAL LOAD	

HT23-549D-ZAA

REVISIONS				
ECO NO.	REV	DESCRIPTION	DATE	APPROVED
6941	A	INITIAL RELEASE	6/16/14	J KORDIK

NOTES, UNLESS OTHERWISE SPECIFIED:

- [1] MEASUREMENTS MADE AT RATED CURRENT IN EACH PHASE.
- [2] BETWEEN ANY TWO ADJACENT STEP POSITIONS.
- [3] MAXIMUM ERROR IN 360°.
- 4. HIPOT 500 VAC, 60 Hz FOR ONE MINUTE.
- [5] LEADS: 8 AWG 24,7 STRAND MIN., UL AND CSA APPROVED, UL 1430 OR UL 3265, CABLE, 8 COND. W/DRAIN, P/N 666-2107.
- 6. INSULATION RESISTANCE: 100 MEGOHMS MIN AT 500 VDC.
- [7] AS MEASURED ACROSS ANY WINDING. RESISTANCE IS DOUBLED WITH BOTH WINDINGS IN SERIES. MEASUREMENTS MADE WITHOUT CABLE.
- [8] AS MEASURED ACROSS ANY WINDING USING AN A.C. INDUCTANCE BRIDGE, AT 1KHz. INDUCTANCE IS FOUR TIMES VALUE WITH WINDINGS IN SERIES. MEASUREMENTS MADE WITHOUT CABLE.
- [9] AS MEASURED BY THE CHANGE IN RESISTANCE METHOD, WITH RATED VOLTAGE APPLIED TO 2 PHASES; WITH MOTOR AT REST.
- 10. HIGH TORQUE MOTOR DESIGN, MICROSTEP LAMINATION.
- 11. ROTOR & STATOR LAMINATED CONSTRUCTION.
- [12] LABEL TO INCLUDE AMPS, MOTOR RESISTANCE, DATE CODE, AMP P/N AND MADE IN TAIWAN.
- [13] DRAIN WIRE TO BE CONNECTED TO INSIDE OF REAR ENDBELL.
- [14] SOLDER CENTER TAP WIRES TOGETHER, WRAP IN SHRINK TUBING AND CONCEAL WITHIN BOOT.
- [15] CURRENT SETTING WHEN USED WITH STAC-6 = 1.5 A
- 16. THIS MOTOR TO BE MANUFACTURED IN COMPLIANCE WITH EU DIRECTIVE "ROHS 2002/95/EC".
- [17] ENCODER 970-1001 INSTALLED PER AMP ASSEMBLY PRACTICES. ENCODER CABLE SOLD SEPARATELY..

LABEL DETAIL

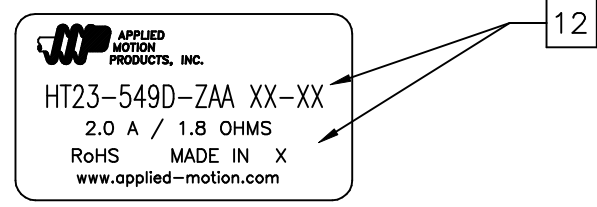

BIPOLAR FULL STEP 2 PHASE ON SERIES CONNECTED

SWITCHING SEQUENCE FOR CW ROTATION FACING MOUNTING END

STEP	WHITE/A+	GREEN/A-	RED/B+	BLACK/B-
0	+	-	+	-
1	-	+	+	-
2	-	+	-	+
3	+	-	-	+
4	+	-	+	-

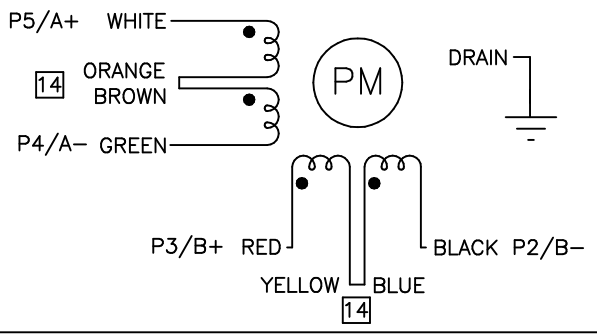

CONTRACT NO.		APPLIED MOTION PRODUCTS, INC.			
APPROVALS	DATE	STEP MOTOR OUTLINE			
DRAWN <i>R.JONEZ</i>	<i>3/17/14</i>				
CHECKED		B	COMPUTER DATA BASE DRAWING	DWG NO. HT23-549D-ZAA	REV A
APPROVED			SCALE: NONE	SHEET 1 OF 2	

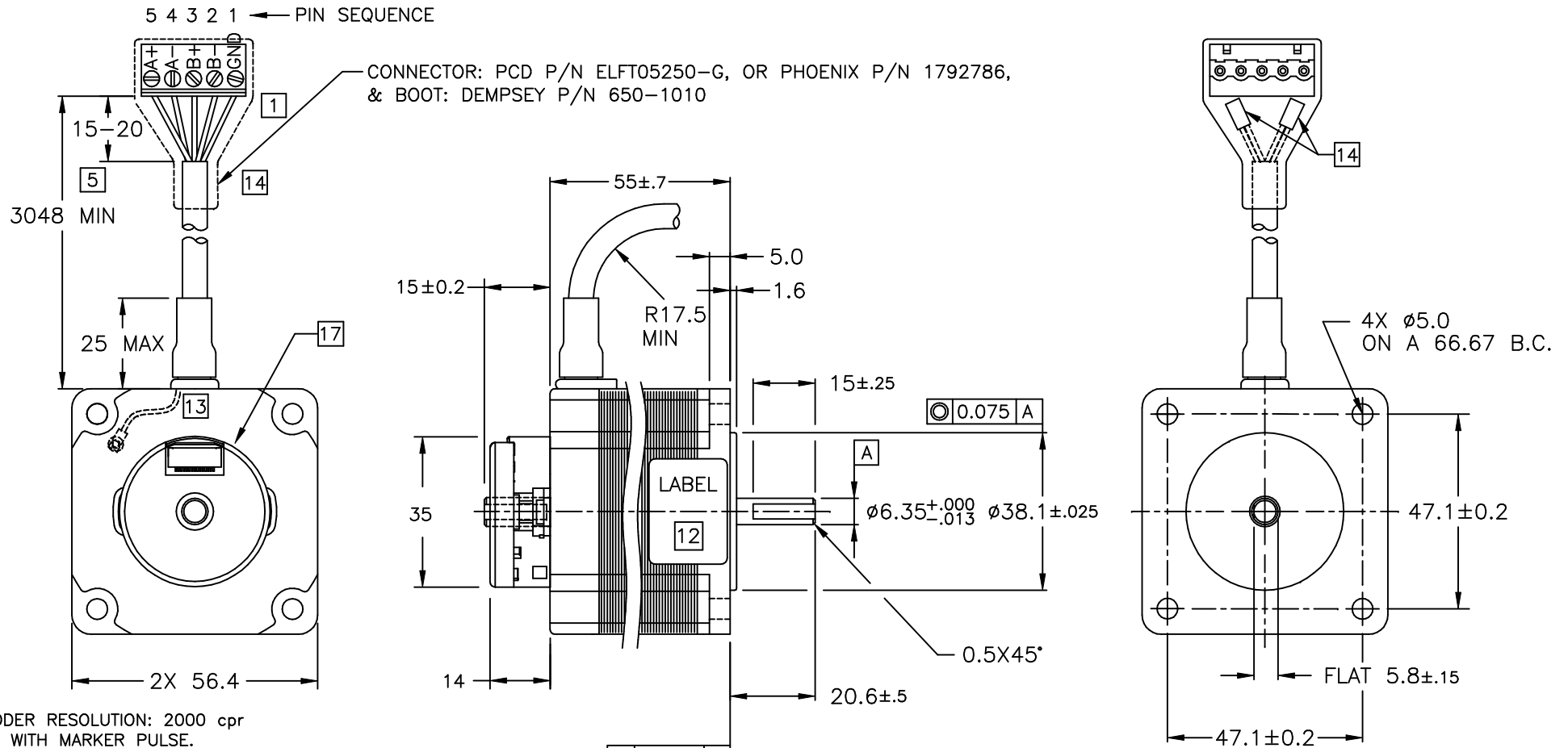

ENCODER RESOLUTION: 2000 cpr
WITH MARKER PULSE.

ENCODER PINOUTS

PIN	SIGNAL
1	CH A
2	CH A-
3	CH B
4	CH B-
5	INDEX
6	INDEX-
7	N/C
8	N/C
9	N/C
10	N/C
11	N/C
12	N/C
13	+Vcc
14	GND
15	N/C

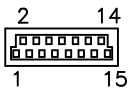

MOTOR CONNECTION CHART		
PIN	CONNECTOR	LEAD COLOR
1	GND	SHIELD
2	B-	BLACK
3	B+	RED
4	A-	GREEN
5	A+	WHITE
YELLOW/ BLUE	SEE NOTE 14	ORANGE/ BROWN

ALL DIMENSIONS ARE IN MILLIMETERS

TOLERANCES		THIRD ANGLE PROJECTION	
DECIMALS: MM (INCH) X.XXX = ± (.005) X.XX = ±0.13 (.010) X.X = ±0.25 (.020) ANGLES: MACH. = ±.5° CHAM. = ±5°			
COMPUTER DATA BASE DRAWING		APPROVALS	DATE
		DRAWN <i>R. JONEZ</i>	3/17/14
		CHECKED	
		APPROVED	
STEP MOTOR OUTLINE			
B	DWG NO. HT23-549D-ZAA	REV A	
SCALE: FULL		SHEET 2 OF 2	