

SPECIFICATIONS:

NUMBER OF PHASES: 2	ROTOR INERTIA: 38 g-cm ² (0.21 oz-in ²) NOM
STEPS PER REVOLUTION: 400	DETENT TORQUE: 12 mNm (1.7 oz-in) MIN
STEP ANGLE: 0.9°	BEARINGS: 625ZZ
STEP TO STEP ACCURACY: ±0.045° [1], [2]	INSULATION CLASS: B
POSITIONAL ACCURACY: ±5% [1], [3]	HYSTERESIS: N/A%
SHAFT RUNOUT: 0.03 mm T.I.R. MAX	TEMP. RISE: 80 °C MAX. [9]
RADIAL PLAY: 0.02 mm MAX (.5KG RADIAL LOAD)	OPERATING TEMP. RANGE: -20 TO+50 °C
END PLAY: 0.08 mm MAX (.5KG AXIAL LOAD)	STORAGE TEMP. RANGE: -30 TO+70 °C
MAXIMUM RADIAL LOAD: 21N (4.72lb)	RELATIVE HUMIDITY RANGE: 15 TO 85 %
MAXIMUM AXIAL LOAD: 10N (2.25lb)	WEIGHT: 0.23 kg (0.51 lb)

	[7]	[8]	[1]	[1]	
SPECIFICATION	RESISTANCE PER PHASE (ohm ±10%)	INDUCTANCE PER PHASE (mH ±20%)	RATED CURRENT (amp)	HOLDING TORQUE (Nm MIN)	HOLDING TORQUE (oz-in Min)
CONNECTION					
BI-POLAR SERIES	20	35	0.5	0.26	36.82

NOTES, UNLESS OTHERWISE SPECIFIED:

- [1] MEASUREMENTS MADE AT RATED CURRENT IN EACH PHASE.
- [2] BETWEEN ANY TWO ADJACENT FULL STEP POSITIONS.
- [3] MAXIMUM ERROR IN 360°.
- 4. HIPOT 500 VAC, 60 Hz FOR ONE MINUTE.
- 5. LEADS: 4, AWG 26, 7 STRAND MIN., UL AND CSA APPROVED, UL 1007
- 6. INSULATION RESISTANCE: 100 MEGOHMS MIN AT 500 VDC.
- [7] AS MEASURED ACROSS EACH PHASE.
- [8] AS MEASURED ACROSS EACH PHASE USING AN A.C. INDUCTANCE BRIDGE AT 1 KHz.
- [9] AS MEASURED BY THE CHANGE IN RESISTANCE METHOD, WITH RATED CURRENT APPLIED TO 2 PHASES; WITH MOTOR AT REST.
- [10] ADD "D" TO END OF PART NUMBER IF DOUBLE SHAFT IS REQUIRED. ENCODER HOLES INCLUDED WITH REAR SHAFT VERSION ONLY.
- 11. ROTOR & STATOR LAMINATED CONSTRUCTION.
- 12. THIS MOTOR IS MANUFACTURED IN COMPLIANCE WITH THE CURRENT EU RoHS DIRECTIVE.
- [13] MOTOR LABEL TO INCLUDE "ROHS" COMPLIANT, AMP P/N, 'MADE IN (COUNTRY OF ORIGIN)', AND DATE CODE.
- 14. HIGH TORQUE MOTOR DESIGN

HT17-221

REVISIONS

ECO NO.	REV	DESCRIPTION	DATE	APPROVED
6947	A	PRELIMINARY RELEASE	4/11/14	D.MACLEOD
7048	B	ERROR CORRECTION	8/11/14	D.MACLEOD
7446	C	REVISE NOTE 12	6/6/16	J KORDIK
8250	D	ADD UL MARK, SPECS	6/5/19	J KORDIK
-	-	-	-	-
-	-	-	-	-
-	-	-	-	-
-	-	-	-	-
-	-	-	-	-
-	-	-	-	-
-	-	-	-	-
-	-	-	-	-

LABEL DETAIL



PHASE DETAIL

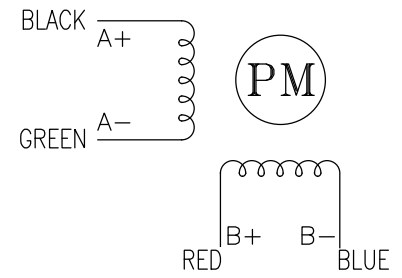

FULL STEP SWITCHING SEQUENCE
BI-POLAR, FACING MOUNTING END

STEP	A+	A-	B+	B-	
0	+	-	+	-	CCW
1	-	+	+	-	
2	-	+	-	+	CW
3	+	-	-	+	
4	+	-	+	-	

CONTRACT NO. -		APPLIED MOTION PRODUCTS, INC.			
APPROVALS	DATE	STEP MOTOR OUTLINE			
DRAWN K. KESLER	8/11/14				
CHECKED -	-	B	COMPUTER DATA BASE DRAWING	DWG NO. HT17-221	REV D
APPROVED -	-		SCALE: NONE	SHEET 1 OF 2	
APPROVED -	-				

2X #2-56 UNC
TAP THRU EQ.SP.
ON A ϕ 32.5 B.C.

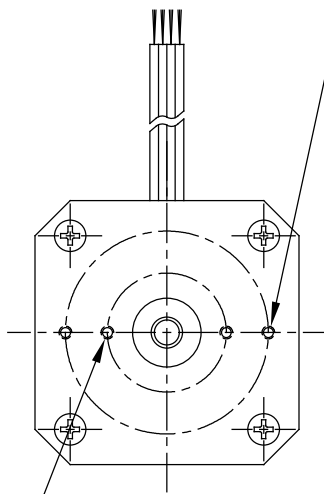

2X #2-56 UNC
TAP THRU EQ.SP.
ON A ϕ 19.05 B.C.

10

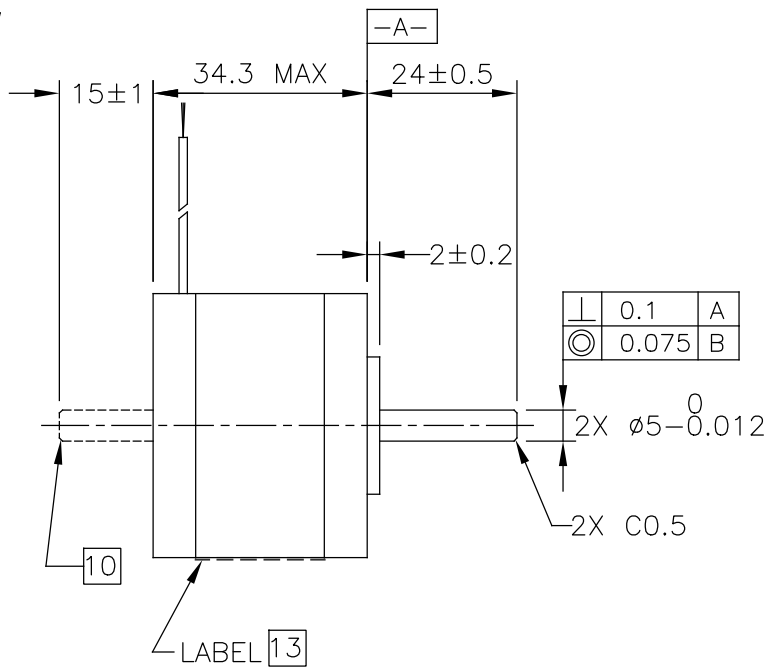

\perp	0.1	A
\odot	0.075	B

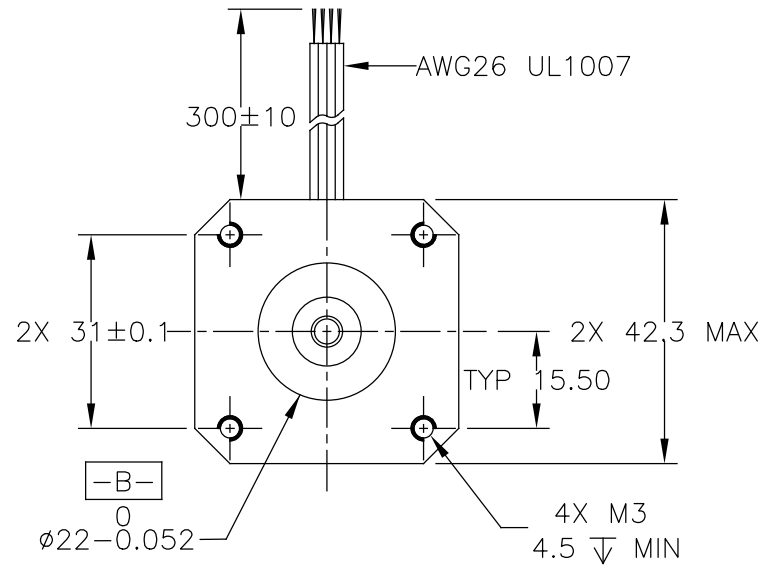

<p>TOLERANCES</p> <p>*ALL DIMENSIONS IN MM</p> <p>DECIMALS: MM</p> <p>X.XX = ± 0.13</p> <p>X.X = ± 0.25</p> <p>ANGLES:</p> <p>MACH. = $\pm 0.5^\circ$</p> <p>CHAM. = $\pm 5^\circ$</p> <p>COMPUTER DATA BASE DRAWING</p>	THIRD ANGLE PROJECTION		<p>APPLIED MOTION PRODUCTS, INC.</p>
	APPROVALS	DATE	<p>B DWG NO. HT17-221</p>
	DRAWN K. KESLER	8/11/14	
CHECKED -	-	SCALE: NONE	SHEET 2 OF 2
APPROVED -	-		