

Mechanical Outline

8/28/00

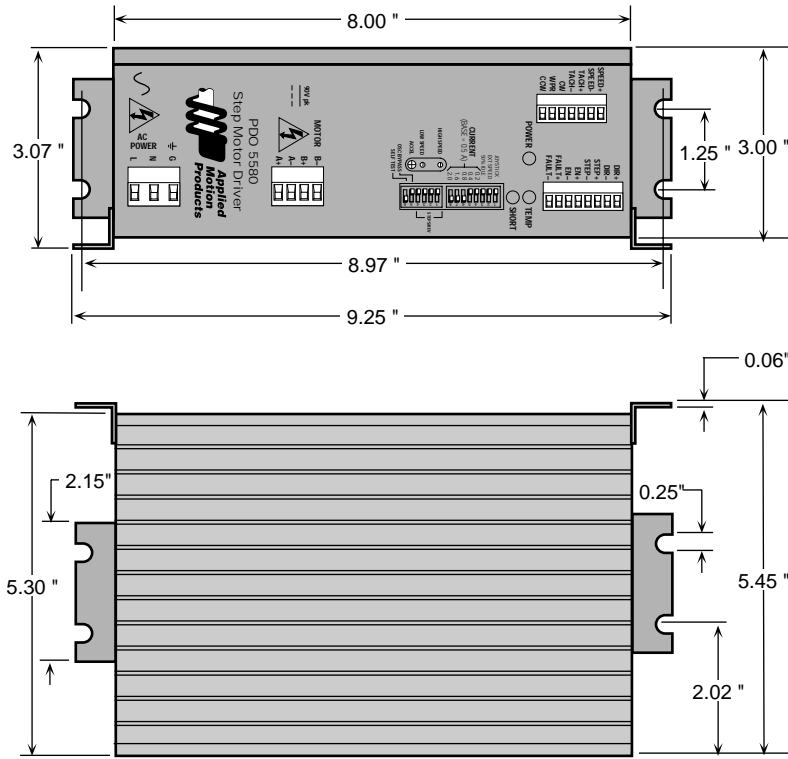

User's Manual

PDO 5580

Step Motor Driver

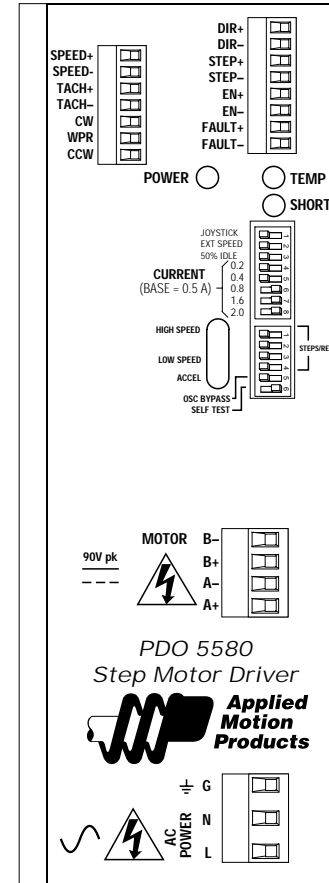

Applied Motion Products, Inc.
 404 Westridge Drive Watsonville, CA 95076
 Tel (831) 761-6555 (800) 525-1609 Fax (831) 761-6544



Introduction

Thank you for selecting an Applied Motion Products motor control. We hope our dedication to performance, quality and economy will make your motion control project successful. If there's anything we can do to improve our products or help you use them better, please call or fax. We'd like to hear from you. Our phone number is (800) 525-1609 or you can reach us by fax at (831) 761-6544.

Features

- Digital oscillator provides smooth accel/decel ramps and precise speed control.
- Powerful microstepping amplifier provides high torque and smooth, quiet motion.
- Accepts a wide range of motors: NEMA sizes 14 - 42, 0.5 to 5.5 amps/phase.
- Easy to configure with on-board switches and potentiometers for all settings.
- Automatic idle current reduction reduces motor and drive heating, saves power.
- Pluggable screw terminal connectors make wiring easy.
- Oscillator Mode operates from internal pots, external pots, 0 - 5 V analog signal, or analog joystick.
- Two speed ranges, can be selected "on the fly" by a digital signal with automatic ramping between speeds.
- Inputs and outputs are optically isolated, differential (sourcing or sinking). Speed & Enable 5 - 24V, Step & Direction 5 - 12V.
- Tach Out signal allows easy measurement of speed.
- Enable input allows motor current to be shut off on command.
- Built in 80 volt power supply (accepts 110 or 220 VAC power, 50-60 Hz)
- MOSFET pulse width modulation switching amplifiers (3 state)
- Microstepping pulse & direction mode with 16 step/rev settings from 200 (full step) through 50,800.
- Overtemp and overcurrent (short circuit) and surge protection
- Built-in self test for troubleshooting.
- CE and TUV compliant.

Technical Specifications (continued)

Recommended Maurey Instrument Corp., Chicago, IL (773)581-4555

Joystick JS31462S5T3 (2 axis) or SAJ2515-F-502 (1 axis)

Speed Ranges LO speed range: 0 - 5 rev/sec
HI speed range: 0 - 25 rev/sec
Accel/decel range: 1 to 250 rev/sec/sec

Physical Constructed with black anodized aluminum heat sink and heavy gauge steel housing. 3 x 5.3 x 8 inches overall. 7.8 lbs. Ambient temperature range: 0 - 70 C. Power, temp and motor short circuit LEDs. Mounting brackets and switch cover included. See back cover for detailed drawing .

Connectors European style, pluggable screw terminal blocks.
Motor: 4 position. Wire size: AWG 12 - 28.
Signal Input/output: 8 position. AWG 16 - 28.
AC Input: 3 position. Wire size: AWG 12 - 28.

CE Mark Complies with EN55011A, EN50082-1(1996), EN50178 (1997).

Technical Specifications

Amplifiers Dual, MOSFET H-bridge, 3 state, pulse width modulated switching at 20 kHz. 0.5 - 5.5 amps/phase output current, switch selectable in 0.2 increments. Overcurrent and overtemperature protection. Automatic idle current reduction (defeatable), reduces current to 50% of setting after one second. Minimum motor inductance is 0.8 mH.

Power Supply Linear, toroidal transformer based for high reliability and low noise. 110 or 220 VAC input, switch selectable. 50-60 Hz. DC voltage at nominal line voltage: 75 VDC full load, 90 VDC no load.

Inputs Speed, Enable: optically isolated, differential 5-24V logic. 2200 ohms internal resistor.

Step, Direction: optically isolated, differential 5 - 12V logic, 680 ohms internal resistance. (24V with external 1000 ohm resistors)

Wiper: 0 - 5 VDC analog signal. Max recommended pot/joystick impedance: 1K - 5K ohms. Joystick dead zone: ± 80 mV. Potentiometer/analog signal dead zone: 40 mV.

In pulse & direction mode, motor steps on falling edge of step input. 0.25 μ sec minimum pulse, 2 MHz max step rate. 1 μ sec minimum set up time, 50 μ s minimum hold time for direction signal.

Outputs Tach & Fault: Optically isolated, uncommitted (open collector, open emitter) photo transistors. 30V, 20 mA max. Tach output is 100 pulses per motor revolution, 50% duty cycle (square wave).

Microstepping Oscillator/joystick modes: 1/64 step (12,800 s/r) with 1.8° motor. Pulse & Direction mode: 16 switch selectable resolutions: 200, 400, 1000, 2000, 5000, 10000, 12800, 18000, 20000, 21600, 25000, 25400, 25600, 36000, 50000, 50800 steps/rev. Self test: 1/2 step.

Getting Started

To use your Applied Motion Products motor control, you will need:

- ✓ a power cable (line cord)
- ✓ a compatible step motor (see page 21)
- ✓ a small flat blade screwdriver for tightening the connectors - an Applied Motion Products screwdriver suitable for this purpose is included with your drive.

For pulse & direction mode:

- ✓ a source of step pulses (usually an indexer is used)

For oscillator mode:

- ✓ an instrument for measuring motor speed (tachometer, freq. counter or o-scope)

For joystick mode:

- ✓ An analog joystick

The sketch below shows where to find the important connection and adjustment points. Please examine it now.

All mating connectors are included.

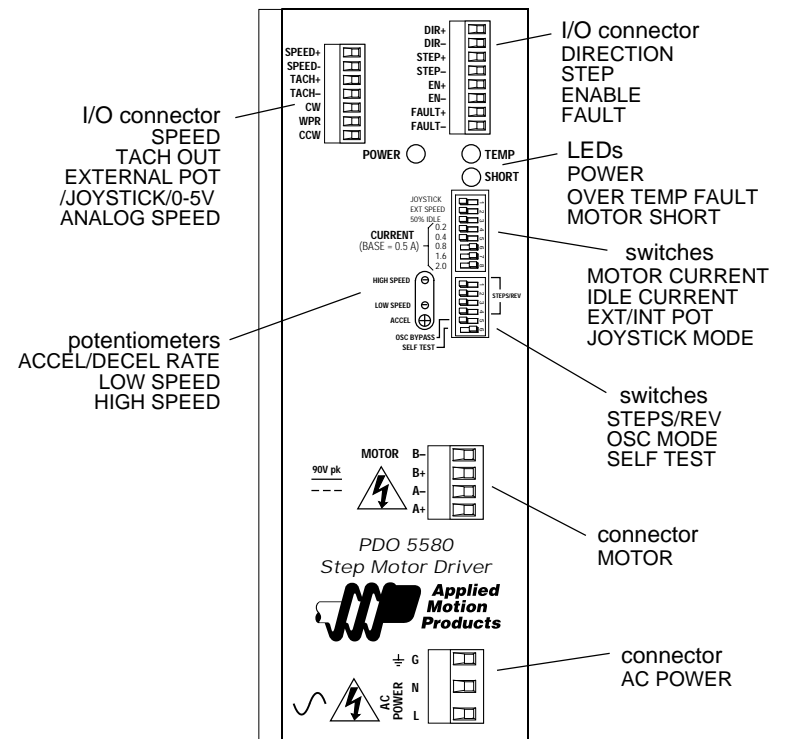

Connecting the AC Line

110 Volts

The PDO 5580 is set for 110 volt operation at the factory. All you need to do is install a power cord and plug it in. If you want to direct wire the PDO 5580 to AC power, you must consult a qualified electrician and observe all building and electrical codes.

The AC cord you can install yourself, but be careful: *AC power can be dangerous.*

220 Volts

The PDO 5580 is set for 110 volt operation at the factory. In order to use 220 volts, you'll need to change a switch setting inside the case. However, you can do this from outside the case with your Applied Motion screwdriver.

Before you can change the 110/220 volt switch setting, you must remove the motor connector and the AC power connector from the drive. Set the drive on the widest side, so that the heat sink fins are pointing upward.

Once you've done that, you'll see an opening in the case, just above the three position and four position green connectors.

If you look into the slot, you should see two black objects. The one on the left is the fuse. The black object to the right of the fuse is the 110/220 volt switch. The sketches below and on page 5 show the two positions of the switch. To change from 110V to 220V, carefully insert your screwdriver into the slot and push the switch to the right.

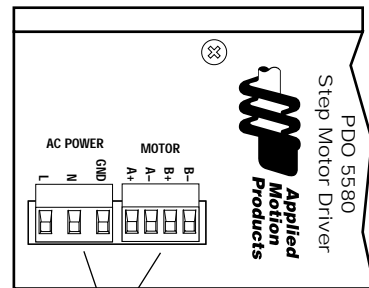

Unplug these connectors

Recommended Motors

The following tables lists motors and current settings that are recommended for the PDO 5580 drive.

Motor Number	Winding Connection	Max Torque oz-in	Max Power Watts	Current Setting Amps/phase
5023-122	parallel	75	60	2.0
5023-123	parallel	120	93	2.5
5023-124	parallel	177	110	3.5
5034-348	parallel	185	133	4.8
5034-349	parallel	300	151	5.0
5034-350	parallel	390	213	5.5
5042-022	parallel	595	300	5.5

Mounting the Drive

You can mount your drive on the wide or the narrow side of the case. Either way you'll need to get the brackets and screws out of the accessory bag and bolt them onto the PDO 5580. If you're mounting on the narrow side, you'll first have to remove one of the screws from the heat sink, then put it back with the bracket in place, as shown in the figure.

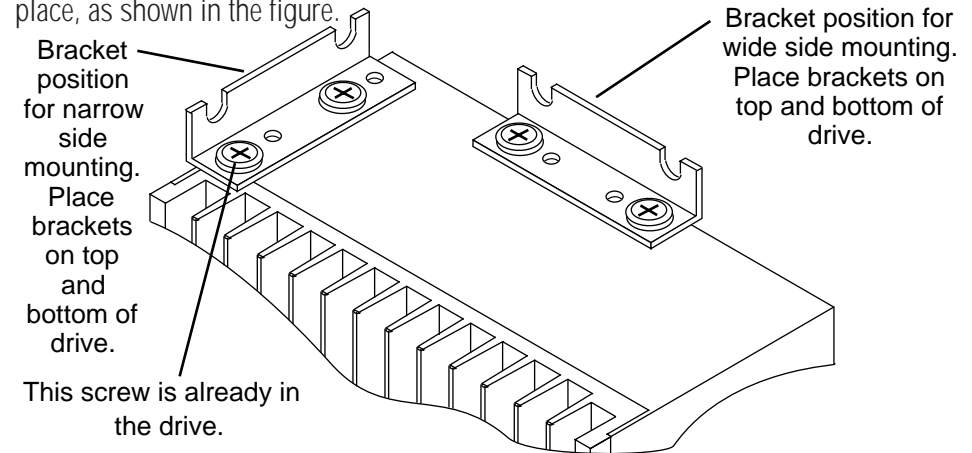

Never use your drive in a space where there is no air flow or where the ambient temperature exceeds 50°C (120°F).
Never block the fins of the heat sink or the vent holes.
Never put the drive where it can get wet.
Never allow metal particles near the drive.

Fault Protection

The PDO 5580 provides protection against motor short circuits and excessive drive temperature.

If the TEMP light is on, the PDO 5580 has detected a thermal problem and shut down the amplifiers. The first thing you should do is to unplug the drive from the power source. Next, touch the heat sink with your fingers. If it is very hot, the drive has probably overheated. Usually this means you need more air flow around the drive.

If the SHORT light is on, the PDO 5580 has detected a short circuit and has shut down the amplifiers. Unplug the drive from the power source. Check the motor wiring carefully. Make sure that the connections to the drive are secure and that any unused motor leads are insulated from the drive and power supply and from each other. Check the motor leads for shorts between phases or to ground.

Using the Fault Output

The PD5580 has a fault output to tell another device (such as a PLC) if the drive has overheats or encounters a short circuit has occurred at the motor outputs. The fault output is optically isolated for noise immunity. This makes it more flexible and more reliable, but also requires a 5, 12 or 24 VDC power source to hook it up. To connect to typical PLC, follow the sketch below.

The photo transistor turns on (closes) when there is a fault.

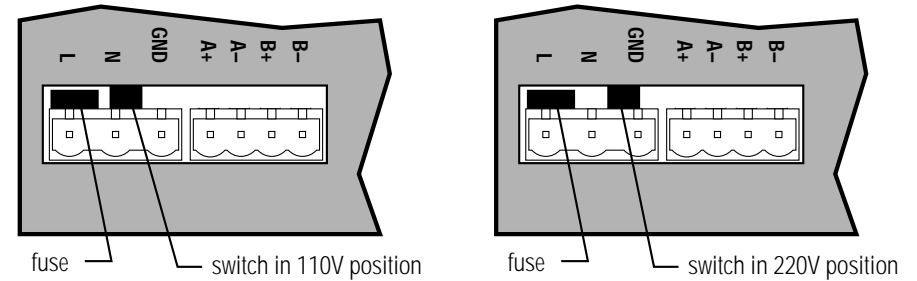
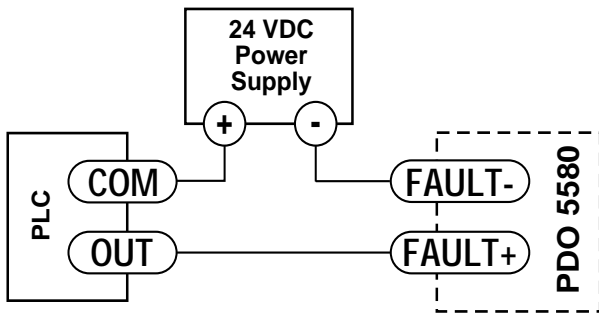

Installing an AC Line Cord

Remove about 5 mm (3/16 inches) of insulation from each of the three wires of your line cord. (That's right, three wires. For safety, always use a three wire power cord on anything with a metal case.) Depending on where you got your power cord, it may have black, white and green wires or brown/blue/green.

The AC power plug that was shipped with your PDO 5580 might be one of two types. The "old style" is shown below, on the left. The "new style" (shown on the right) comes with an insulating rubber boot.

Make sure you follow the proper sketch your connector style.

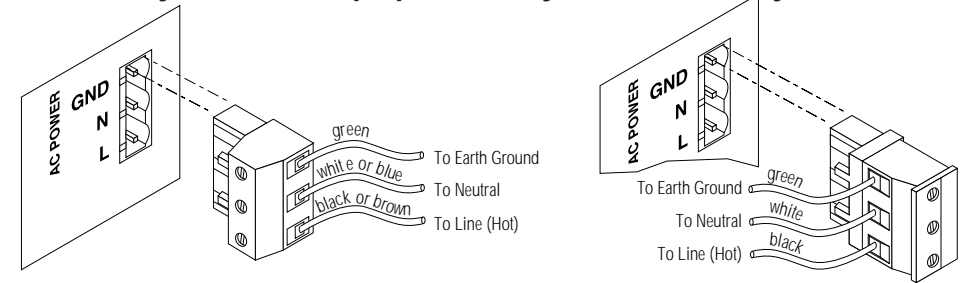

**"Old Style"
AC Power Plug**

**"New Style"
AC Power Plug**



Always unplug the line cord from the wall before attaching it to the PDO 5580

- Connect the black or brown wire to the PDO 5580 "L" terminal of the AC power connector. That is the line, or "hot" connection.
- Connect the white or blue wire to neutral. That's the "N" terminal.
- Finally, and most importantly, connect the green wire to the GND terminal. That connects the PDO 5580 metal enclosure and DC power supply ground to earth ground.

Connecting the Motor



Never connect the motor to the driver when the AC power is on.
Secure any unused motor leads.
Never disconnect the motor while the AC power is on.
Never connect motor leads to ground or to a power supply.

You must now decide how to connect your motor to the drive.

Four lead motors can only be connected one way. Please follow the sketch at the right.

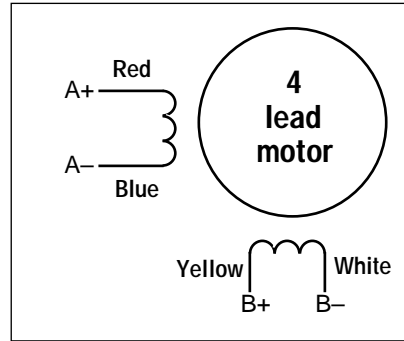

4 Leads

Six lead motors can be connected in series or center tap. In series mode, motors produce more torque at low speeds, but cannot run as fast as in the center tap configuration. In series operation, the motor should be operated at 30% less than the rated current to prevent overheating. Wiring diagrams for both connection methods are shown below.

Note: NC means not connected to anything.

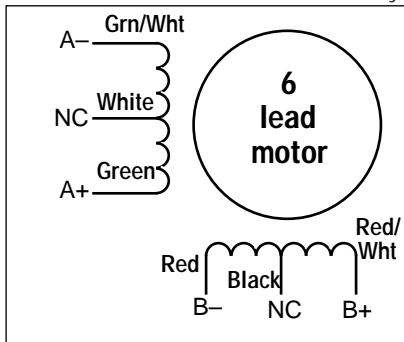

6 Leads Series Connected

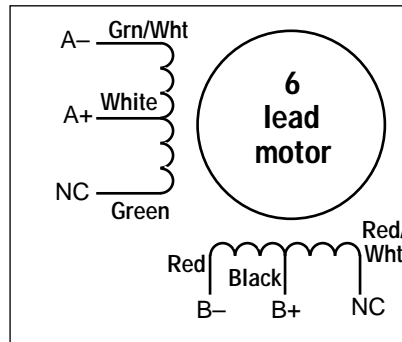

6 Leads Center Tap Connected

Current Setting Table

0.5 AMPS/ PHASE	1.9 AMPS/ PHASE	3.3 AMPS/ PHASE	4.7 AMPS/ PHASE
0.7 AMPS/ PHASE	2.1 AMPS/ PHASE	3.5 AMPS/ PHASE	4.9 AMPS/ PHASE
0.9 AMPS/ PHASE	2.3 AMPS/ PHASE	3.7 AMPS/ PHASE	5.1 AMPS/ PHASE
1.1 AMPS/ PHASE	2.5 AMPS/ PHASE	3.9 AMPS/ PHASE	5.3 AMPS/ PHASE
1.3 AMPS/ PHASE	2.7 AMPS/ PHASE	4.1 AMPS/ PHASE	5.5 AMPS/ PHASE
1.5 AMPS/ PHASE	2.9 AMPS/ PHASE	4.3 AMPS/ PHASE	
1.7 AMPS/ PHASE	3.1 AMPS/ PHASE	4.5 AMPS/ PHASE	

Setting Phase Current

Before you turn on the power supply the first time, you need to set the driver for the proper motor phase current. The rated current is usually printed on the motor label. The current you set on the PDO 5580 is the peak current, not RMS.

The PDO 5580 drive current is easy to set. If you wish, you can learn a simple formula for setting current and never need the manual again. Or you can skip to the table on the next page, find the current setting you want, and set the DIP switches according to the picture.

Current Setting Formula

Locate the bank of eight switches. Five of the switches have a value of current printed next to them, such as 0.2 and 1.6. Each switch controls the amount of current, in amperes (A), that its label indicates. There is always a base current of 0.5 A. To add to that, slide the appropriate switches toward their labels. You may need your small screwdriver for this.

Example

Suppose you want to set the driver for 2.9 amps per phase. You need the 0.5 A base current plus another 2.0 and 0.4 A.

$$2.9 \text{ (TOTAL)} = 0.5 \text{ (BASE)} + 2.0 + 0.4$$

Slide the 2.0 and 0.4 A switches toward the labels as shown in the figure.

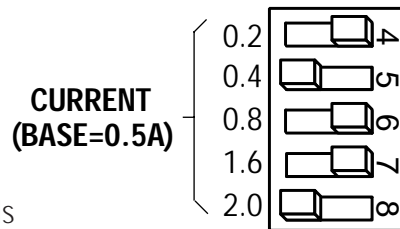

Idle Current Reduction

Your drive is equipped with a feature that automatically reduces the motor current by 50% anytime the motor is not moving. This reduces drive heating by about 50% and lowers motor heating by 75%. This feature can be disabled if desired so that full current is maintained at all times. This is useful when a high holding torque is required. To minimize motor and drive heating we highly recommend that you use the idle current reduction feature unless your application strictly forbids it. Idle current reduction is enabled by sliding switch #3 toward the 50% IDLE label, as shown in the sketch below. Sliding the switch away from the 50% IDLE label disables the reduction feature.



Idle Current Reduction Enabled



Idle Current Reduction Disabled

Eight lead motors can also be connected in two ways: series and parallel. As with six lead motors, series operation gives you more torque at low speeds and less torque at high speeds. In series operation, the motor should be operated at 30% less than the rated current to prevent overheating. The wiring diagrams for eight lead motors are shown below.

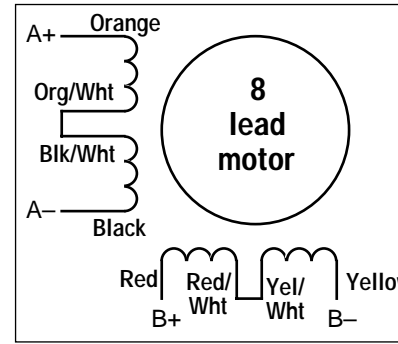

8 Leads Series Connected

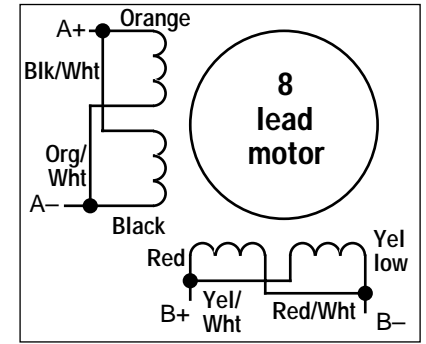

8 Leads Parallel Connected

Step Table (full stepping)

Step	A+	A-	B+	B-
0	+	-	+	-
1	+	-	-	+
2	-	+	-	+
3	-	+	+	-
4	+	-	+	-

Step 0 is the Power Up State

DIR=1
CW

DIR=0
CCW

Modes of Operation

The PDO 5580 has four modes of operation, selected by three dip switches.

Self Test Mode is used for trouble shooting. If you are unsure about the motor or signal connections to the drive, or if the PDO 5580 isn't responding to your step pulses, you can turn on the self test.

To activate the self test, slide switch #6 toward the TEST label. The drive will slowly rotate the motor, 1/2 revolution forward, then 1/2 rev backward. The pattern repeats until you slide the switch away from the TEST label. The PDO 5580 always uses half step mode during the self test, no matter how you set the steps/rev switches. The self test ignores the STEP and DIRECTION inputs while operating. The ENABLE input continues to function normally.

Pulse & Direction Mode - the PDO 5580 receives step pulses from an indexer such as the Applied Motion Si-1 or Si-100. Steps/revolution are set by switches 1 - 4 (see pages 10 - 11).

Joystick mode - speed and direction are determined by an external analog voltage. STEP and DIR inputs can be used for limit switches. SPEED input selects speed range. LO SPEED and HI SPEED pots adjust the 2 speed ranges.

Oscillator mode - speed can be controlled by on-board potentiometers and/or by an external analog voltage. STEP input starts and stops the motor. DIR input controls direction of rotation. SPEED input selects the speed range.

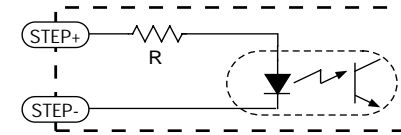
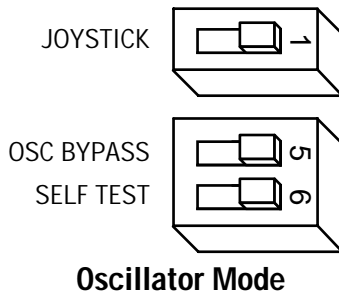
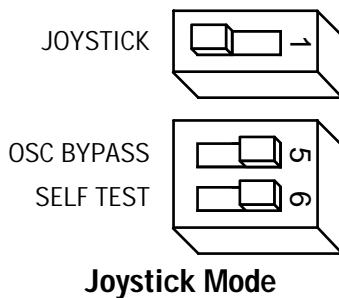
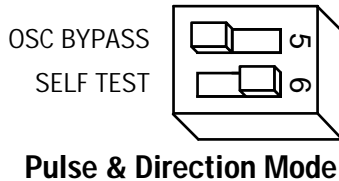
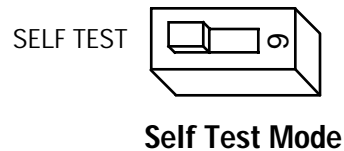

PDO 5580 Input Circuit

Sinking Circuits (NPN)

If your output devices prefer to sink current, then connect the "+" terminals to your positive power supply, and the "-" terminals to your signals (i.e. STEP-, DIR-, etc.). If you are using a TTL circuit to drive the PDO 5580, connect the "+" terminals to your 5 volt bus. No ground connection is needed. If you are using a PLC or proximity sensor, you'll need a power supply.

Sourcing circuits (PNP)

If your output devices can only source current (some PLC outputs are this way), connect the "-" terminals to the ground of the DC power supply that powers your output circuits. Then connect your signals to the "+" terminals (STEP+, DIR+, etc.)

Note: We refer to an input as being ON when current is flowing through the input. A signal is OFF when no current is flowing. An input is OFF when COM and the input terminal are at the same voltage, or when the input is left unconnected (open).

Tach Output

The Tach Out signal is provided for measuring the motor speed. It generates 100 pulses per revolution, so if you connect a frequency counter, the speed reads out in revs/second with two decimal places.

Do not connect the Tach output to more than 24VDC.

The current into the Tach+ terminal must not exceed 20 mA.

Enable Input

ENABLE allows the user to turn off the current to the motor by setting this signal to logic 0. The logic circuitry continues to operate, so the drive "remembers" the step position even when the amplifiers are disabled. However, the motor may move slightly when the current is removed depending on the exact motor and load characteristics. **If you have no need to disable the amplifiers, you don't need to connect anything to the ENABLE input.**

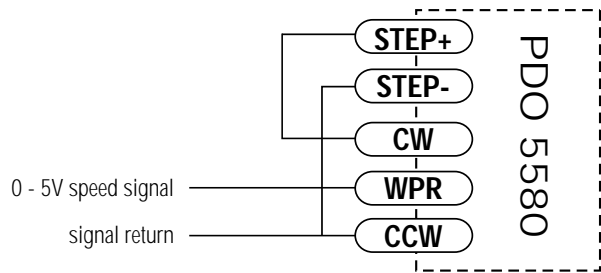

Wiring for Speed Control by 0 - 5 Volt Analog Signal (Unidirectional)

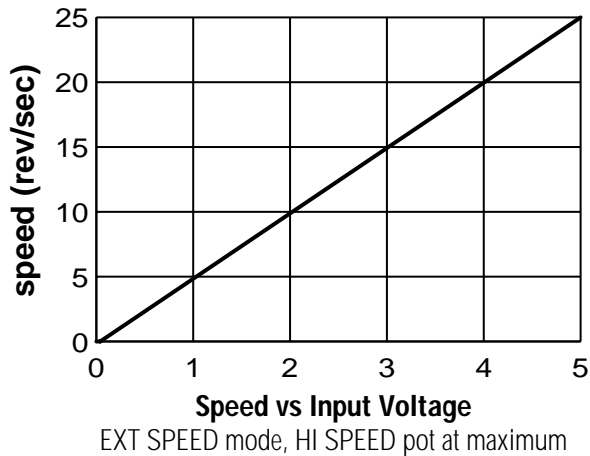

Connecting Digital Inputs and Limit Switches

The PDO 5580 contains optical isolation circuitry to prevent the electrical noise inherent in switching amplifiers from interfering with your circuits. This arrangement also allows a wide range of input voltages to be used and gives you the option of using sinking or sourcing inputs.

A schematic diagram of the input circuit is shown on the next page.

You must supply 5-12 volts DC to supply current to the LEDs on the input side of the optoisolators. 24 VDC is acceptable for the SPEED and ENABLE inputs. You can operate the STEP and DIR inputs at 24V if you add a 1000 ohm resistor to each input. Most CMOS and open collector TTL devices are directly compatible with this drive, as are typical PLC and proximity sensor outputs.

Setting up For Pulse & Direction Mode

You must:

- ✓ Connect an indexer/controller to the Step and Direction inputs.
- ✓ Set the steps/rev.
- ✓ Turn off the SELF TEST switch and turn on the OSC BYPASS switch.

Differential Logic

If your controller has STEP+, STEP-, DIR+ and DIR- outputs, which many indexers do, the connections are simple. Just connect STEP+ to STEP+, STEP- to STEP- and so forth, as shown below.

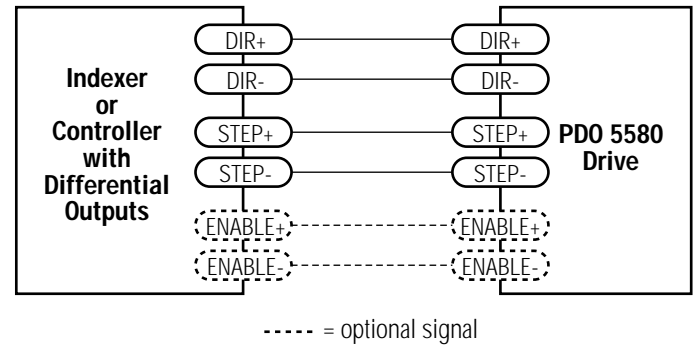

Sinking Logic

If your controller has STEP, DIR and +5V outputs, like the Applied Motion Products SI-1 indexer, connect STEP+ and DIR+ to +5V. Connect STEP- to STEP. Connect DIR- to DIR.

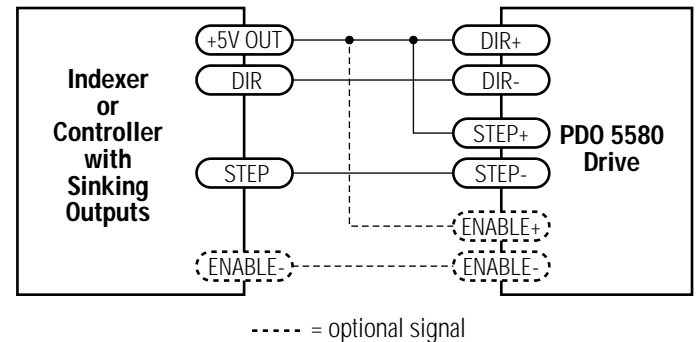

Sourcing Logic

If your controller has STEP, DIR and GND (ground or common) outputs, connect STEP- and DIR- to GND. Connect STEP+ to STEP. Connect DIR+ to DIR.

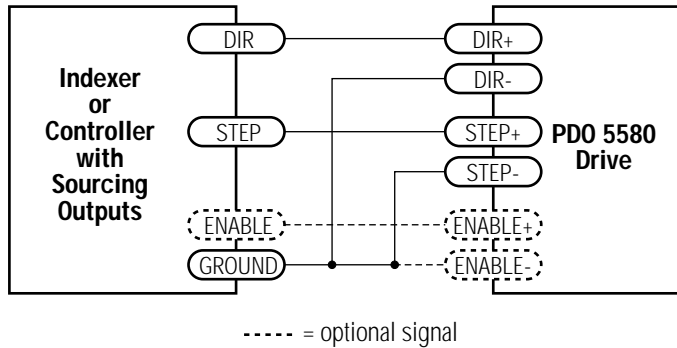

Microstepping

Most step motor drives offer a choice between full step and half step resolutions. In full step mode, both motor phases are used all the time. Half stepping divides each step into two smaller steps by alternating between both phases on and one phase on.

Microstepping drives like the PDO 5580 precisely control the amount of current in each phase at each step position as a means of electronically subdividing the steps even further. The PDO 5580 offers a choice of full and half step as well as 14 other step resolutions. The highest setting divides each full step into 254 microsteps, providing 50,800 steps per revolution when using a 1.8° motor.

In addition to providing precise positioning and smooth motion, microstep drives can be used for motion conversion between different units. The 25,400 step/rev setting is provided as a means of converting motion from metric to english. (There are 25.4 mm in an inch.) Other settings provide step angles that are decimal degrees (36,000 steps/rev makes the motor take 0.01° steps.) Some settings are used with lead screws. When the drive is set to 2000 steps/rev and used with a 5 pitch lead screw, you get .0001 inches/step.

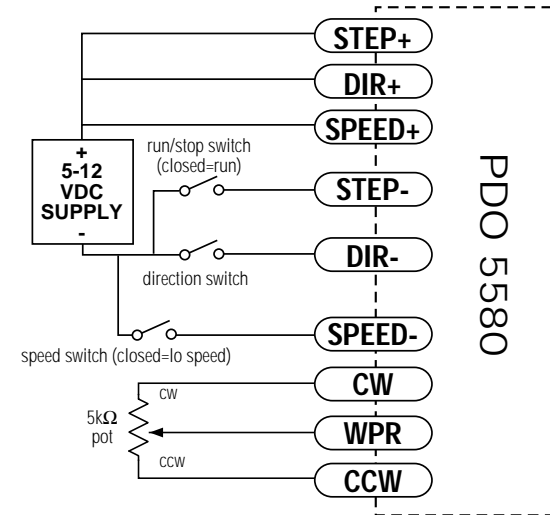

Typical Wiring for Oscillator Mode Using External Speed Control Pot

Speed Control from a 0 to 5 Volt Analog Signal

In oscillator mode, the PDO 5580 can rotate the motor at a speed proportional to an analog voltage. The voltage must be applied to the WPR terminal. The direction of rotation is controlled by the digital DIR input and the motor can be stopped either by setting the analog input voltage to 0 or by turning the digital STEP signal off.

To use the PDO 5580 in this mode, set switch #1 away from the JOYSTICK label, and set switch #2 toward the EXT SPEED label.



The HI SPEED pot sets the maximum speed (the motor speed when the analog signal is at 5 volt DC). The range is 0 - 25 rev/sec. Wiring diagrams and a plot of speed vs voltage are shown below and on the next page.

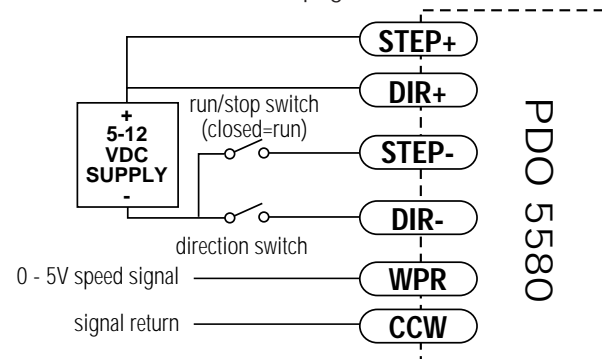

Wiring for Speed Control by 0 - 5 Volt Analog Signal (with Dir Control)

There are two speed ranges in oscillator mode. One is the low speed range, which is activated when the SPEED input is on. The low speed can be set from 0 to 5 rev/sec (0 - 300 rpm) by adjusting the LO SPEED pot. Turning the pot clockwise increases the speed.

The high speed setting is used when the SPEED input is off, or open. If switch #2 is toward the words EXT SPEED, then the high speed is proportional to the voltage applied to the WPR terminal, and is trimmed by the HI SPEED pot. You can connect an external 1K - 5K pot to the WPR, CW and CCW terminals, or you can apply a 0 to 5 volt analog signal to the WPR terminal (ground your analog signal to the CCW pin.) The high speed range is 0 - 25 rev/sec (0 - 1500 rpm.) You can reduce the range by turning down the HI SPEED pot. For example, if you want the motor to go 750 rpm when the external pot is on maximum, turn the HI SPEED pot down about half way.

When switch #2 is away from the EXT SPEED label, the high speed is set by the HI SPEED pot and the WPR input does nothing.

Never apply more than 5 volts DC or less than 0 volts to the WPR pin.

In joystick and oscillator modes, the accel/decel rate is set by the ACCEL pot.

The range is 1 to 250 rev/sec/sec. Turning the pot clockwise makes the motor start and stop faster, but if you set it too high the motor may run out of torque and stall.

In nearly all cases, the accel/decel rate you set is respected by the PDO 5580. For example, if you switch the SPEED input while the motor is moving, the drive will change speeds smoothly. If you are operating in EXT SPEED mode and make a sudden change in the voltage to the WPR terminal, the drive accelerates (or decelerates) to the new speed smoothly, according to the accel pot setting.

The only time the drive makes an instant change is when the SPEED input is on and the STEP input goes off. That is done so that you can stop instantly (and exactly) from a low speed.

Selecting Microstep Resolution

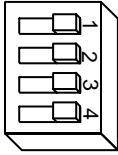
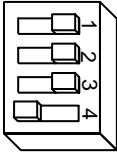
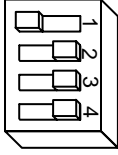
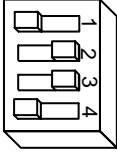
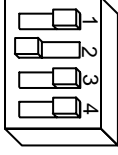
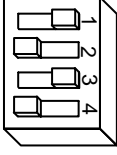
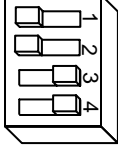
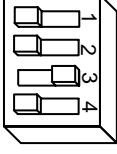
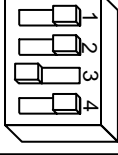
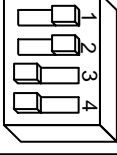
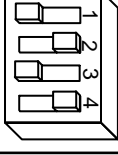
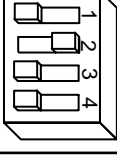
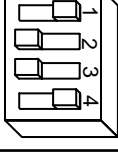
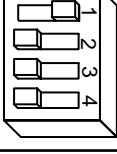
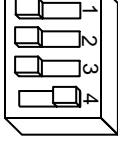
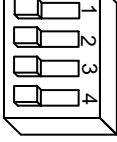
200 STEPS/REV (FULL)	MICROSTEP RESOLUTION		20000 STEPS/REV (1/100)	MICROSTEP RESOLUTION	
400 STEPS/REV (HALF)	MICROSTEP RESOLUTION		21600 STEPS/REV (1 arc min)	MICROSTEP RESOLUTION	
1000 STEPS/REV (1/5)	MICROSTEP RESOLUTION		25000 STEPS/REV (1/125)	MICROSTEP RESOLUTION	
2000 STEPS/REV (1/10)	MICROSTEP RESOLUTION		25400 STEPS/REV (1/127)	MICROSTEP RESOLUTION	
5000 STEPS/REV (1/25)	MICROSTEP RESOLUTION		25600 STEPS/REV (1/128)	MICROSTEP RESOLUTION	
10000 STEPS/REV (1/50)	MICROSTEP RESOLUTION		36000 STEPS/REV (.01°)	MICROSTEP RESOLUTION	
12800 STEPS/REV (1/64)	MICROSTEP RESOLUTION		50000 STEPS/REV (1/250)	MICROSTEP RESOLUTION	
18000 STEPS/REV (.02°)	MICROSTEP RESOLUTION		50800 STEPS/REV (1/254)	MICROSTEP RESOLUTION	

Joystick Mode

In this mode, speed and direction are determined by the voltage applied to the WPR (wiper) terminal. 2.5 volts is “stopped” (no speed). Increasing the WPR voltage toward 5 volts results in forward motion: speed increases with voltage. Decreasing the WPR voltage from 2.5 toward 0 results in reverse motion, with speed increasing as voltage decreases. In joystick mode, the PDO 5580 operates at 12800 steps/rev.

The maximum speed is determined by two things: the state of the SPEED input and the HI SPEED and LO SPEED trimpots. When the SPEED input is ON, the speed range of the joystick can be adjusted with the LO SPEED pot, up to 5 rev/sec (300 rpm) When the SPEED input is OFF (or open), the joystick speed range is adjusted with the HI SPEED pot, up to 25 rev/sec (1500 rpm). Turning the pots clockwise increases the speed.

In joystick mode, limit switches can be connected to the PDO 5580 to prevent motion outside of defined limits. The forward limit should be connected to the STEP input and the reverse limit should be connected to the DIR input. When the forward limit is ON, the motor will not move forward (that is, when the joystick voltage is between 2.5 and 5 volts.) When the reverse limit is ON, the motor will not move when the joystick is in the 0 to 2.5 volt range. If you don't need limits, you can leave the STEP and DIR inputs unconnected.

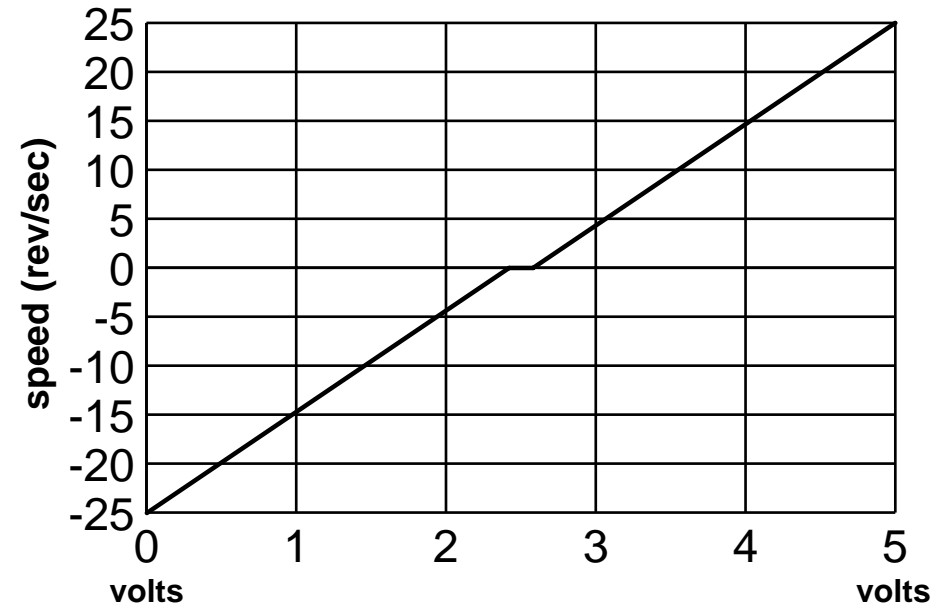
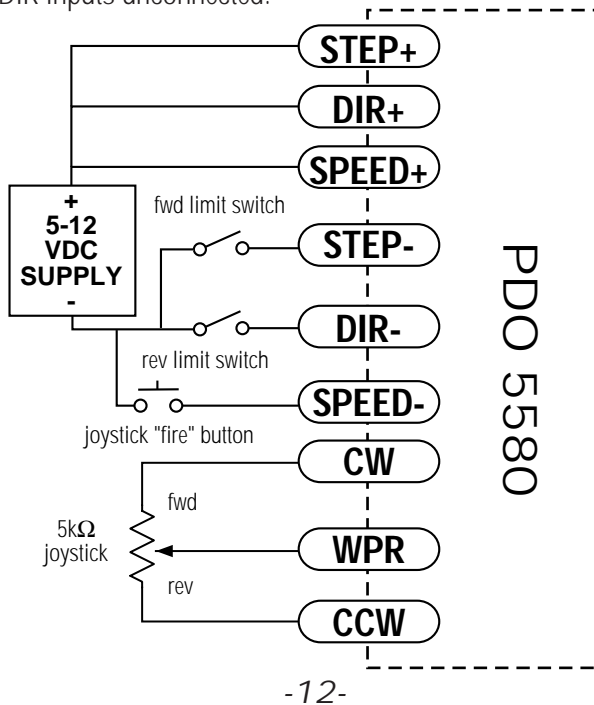

Speed vs Input Voltage

Joystick Mode, SPEED input off (open)
HI SPEED pot at maximum

Oscillator Mode

In oscillator mode, the PDO 5580 uses the direction set by the DIR input. Off, or open, gives clockwise motion, if the motor is wired according to pages 6 and 7. Motor speed and the function of the STEP input can be determined from the following table. In oscillator mode, the PDO 5580 operates at 12800 steps/rev.

SPEED input	switches 1 & 2	speed set by	when STEP goes ON	when STEP goes OFF
ON	joystick ext speed	LO SPEED	accel to speed	instant stop
ON	joystick speed	LO SPEED	accel to speed	instant stop
OFF/open	joystick ext speed	HI SPEED	accel to speed	decel to stop
OFF/open	joystick speed	WPR input trimmed by HI SPEED	accel to speed	decel to stop